



ProLift™ SCISSOR LIFT

PL-2500-SL

Setup & Operating Manual



Adaptive Technologies Group, Inc
1635 E. Burnett Street
Signal Hill, CA 90755 USA

Table of Contents

Table of Contents.....	2
Overview.....	3
Safety.....	4
System Components.....	5
Install Docking Frame.....	6
Install Scissor Lift Assembly.....	6
Install the DEC Digital Control Box.....	7
Install the Remote Wall Switch.....	8
Prepare for Testing the Lift.....	9
Identifying the Limit Switches.....	10
Limit Switch Adjustment Procedure.....	11
Setting the Up & Down Limits.....	12
Setting Up the Show Position.....	12
Operating the Scissor Lift.....	13
Install the X-Y Projector Interface.....	14
Install a Projector Enclosure.....	15
Attaching the Cable Side Cars and Wire Tracks.....	16
Annual Maintenance / Inspection.....	17
Troubleshooting.....	18
Digital Controller Schematic & Date.....	19
Digital Controller Programming.....	20

OVERVIEW – READ THIS FIRST

- This manual provides instructions on how to install, set up and operate the PL-2500-SL Scissor Lift. Use the diagrams and illustrations to guide the installation. **Use experienced professionals only.**
- Prepare an overhead structure that will support the weight and size of the Scissor Lift, its Docking Frame, the projector, cabling and additional accessories. At minimum, the working load should be 1100 lb/500 kg and all six (6) attach points must be used to secure the Docking Frame to the overhead structure using ½-13 X 1-3/8” or M12 X35mm grade 8 bolts, washers and lock nuts.
- Verify that there is sufficient overhead space for the Scissor Lift. Allow for 55” width x 55” length or more clearance from the ceiling down to the floor and that there is vertical travel clearance of 8’ - 0” (2500 mm) or less below the Lift, less the depth of the projector or projector enclosure.
- Be sure the lift will rise to the upper-most position and lower to the service height. If a projector enclosure is installed, lower it onto a pedestal to avoid swaying, but **do not over-travel to avoid unspooling its cable.**
- Bring electrical power for both the Lift and the Projector, as well as accessories into the area where the Lift’s digital controller will be installed. The Lift requires 230VAC single phase AC, 60 hz 20 amps. Provide electrical requirements of the projector and additional equipment to the electrical contractor.
- Hoist equipment is required to hoist the Scissor Lift into place. Allow for up to 500 lb/ 227 kg of payload, not including tools and personnel. **Use experienced riggers and electro-mechanical contractors only.**
- The Scissor Lift comes pre-assembled with restraining straps that secure the top and bottom frame of the Lift together. **Do not remove these straps, until instructed to do so.** Cable side cars and wire track are packed separately and come unassembled.
- The DEC Digital Control Box may be installed onto the two vertical tabs at the back of the Scissor Lift or to another location, within six feet (2 meters) of the Lift’s connector panel. Also, be sure the Lift’s motor cable will reach the Digital Control Box and that power is installed nearby.
- Install the Remote Switch Box at a comfortable height, below the Lift, and at least six feet from where the lift is lowered. The operator must always have sight of the Lift as it is raised and lowered.
- Carefully set and test the Lift’s limit switches into the desired show, stow and maintenance positions.

- Attach an X-Y Interface kit to the Scissor Lift when installing a projector directly to the Lift.

SAFETY TIPS - Follow this guide to ensure a safe installation

Electrical / Shock Hazards: The Scissor Lift operates on 230 VAC and comes with a NEMA rated wall plug. The Lift may also be hard wired, which should be performed by a certified electrician.

Pinch / Obstructions: This Lift design includes a series of arms arranged in a scissor pattern that when retracted presents a pinch hazard. Be certain that hands and fingers are clear of these arms during the operation, as well as any loose wiring, cables, etc.

Fall Arrestors: In the extremely unlikely event that the Scissor Lift and projector should free fall, two load rated fall protection assemblies will engage to prevent the fall. Do not tamper with these devices nor loosen its hardware for any reason.

Overhead Clearances: Check the area in which the Lift will be installed to be sure that it will not interfere with existing equipment such as cables, HVAC, electrical or fire safety devices.

Safe Operating Distance: The up/down remote wall switch must be located at least 6 feet perpendicular to where the Lift lowers and must always be visible to the operator.

Limit Switch Settings: Small adjustments to limit switch settings cause large changes to Lift positions.

Make small incremental adjustments, back and forth, until the desired positions have been determined.

Suspension Load: A Scissor Lift system's installation is rated for a maximum gross weight of 1500 lb./682 kg., including the Lift, interface frame, projector, cabling, accessories and a projector enclosure.

Lifting Load: This Scissor Lift is rated for a maximum lifting load for the PL-2500-SL is 600 lb/473 kg. which includes the projector, projector equipment, cabling and a projector enclosure.

Retraining Straps: The Scissor Lift assembly comes pre-assembled with restraining straps that must remain attached until instructed to remove them.

Cable Spoolers: Once the retaining straps have been removed from the Lift assembly, cable Spoolers reel the Lift's payload up and down and must remain in tension at all times. Do not **fully** lower the lift onto a structure. Keep the load in tension at all times to avoid unspooling the Lifting Cable.

Should the Cables come unspooled, see trouble-shooting on page 18.

System Components

The following is an installation and instruction manual for the ProLift™ Series Scissor lifts. Be sure that all of the following items are included in this shipment before proceeding:

1 pc. Scissor Lift Chassis – Includes the motor, gear box, limit switches, Lifting Cables and Cable Spoolers.

1 pc. Docking Frame – Used to secure the lift to the facility’s overhead structure. See Pg. 7

1 pc. DEC Digital Controller – Select from the PL-SL-DEC for two position control, the PL-SL-DEC3 for three position control, or the PL-SL-DEC+ that communicates with show controllers. Includes lockable steel box, limit switch cables, and a remote wall switch in a lockable steel box. Each Controller mounts on or near the Scissor Lift, powers the motor and controls the up/down motion and powers the motor. See pg. 9

1 pc. Remote Wall Switch – A push button controller in a lockable & wall mountable enclosure. Includes a 30-foot-long cable, Micro M12 connector. Optional extended length cables are also available. See pg. 9

2 pcs. Side-Car Cable Carriers – Two basket assemblies that hold the Cable Tracks, come with but are not assembled to the Lift. One Cable Track per side of the Lift. One supports the power cable, the other for signal and data wires. Shown below. See page 16

2 pcs. Cable Tracks – Two sets of 8’ cable track that is used to provide power and data/signal to the projector. Shown Below.

1 set Enclosure Cables – 4 pcs 6’ limit switches, 1 pc. 30’ remote switch cable, 1 pc. Digital Controller cable.

Scissor Lift Chassis

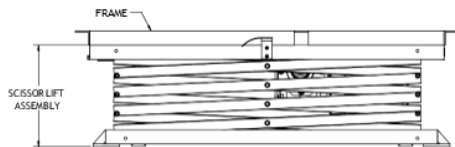

Remote Wall Switch

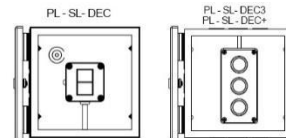

Cable Track

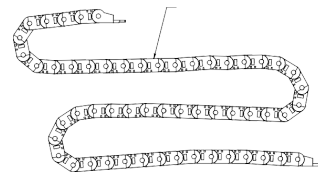

Digital Controller

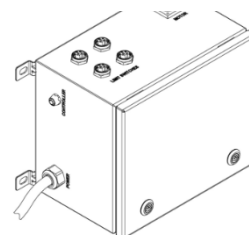

Docking Frame

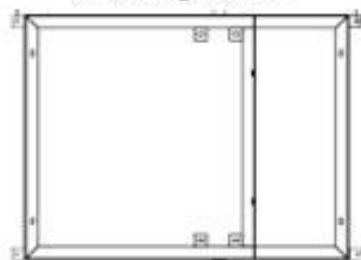

Cable Carrier

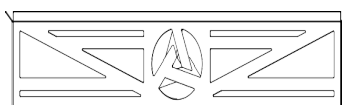

Install the Docking Frame - Secure the Docking Frame permanently to a pre-installed overhead structure using the provided grade 8 hardware at all six mounting hole locations. The frame must be leveled horizontally, and the front of the frame must be facing the projection screen. This Frame, attachment hardware, and the structure above it must be capable of supporting a minimum of 1500 lb./682 kg.

Install the Scissor Lift Assembly – Use a lift or hoist to bring the Scissor Lift up to the Docking Frame. Attach the Scissor lift assembly permanently to the Docking Frame with the front of the Lift facing toward the screen and the motor facing the floor. Use the included grade 8 bolts, washers and nuts.

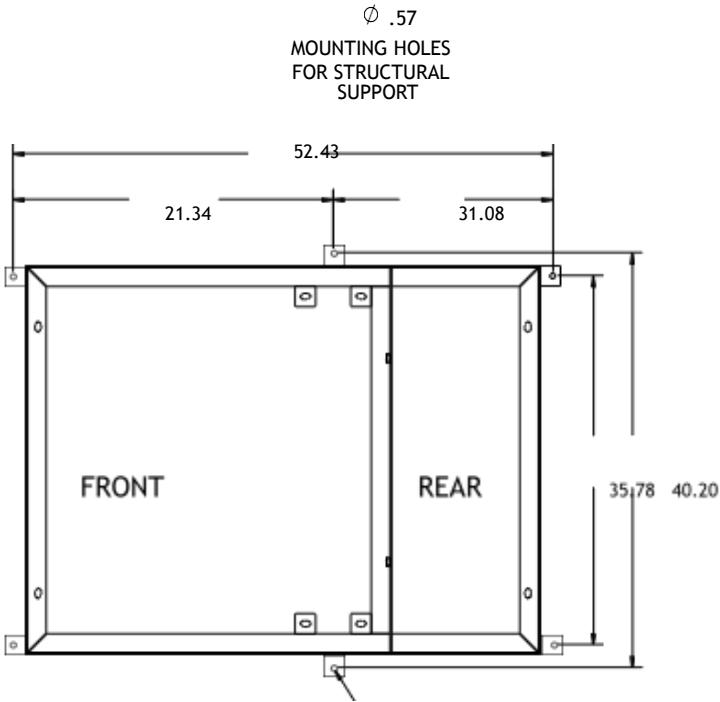

Use Grade 8 or equivalent hardware. All 6 provided mounting holes must be used.

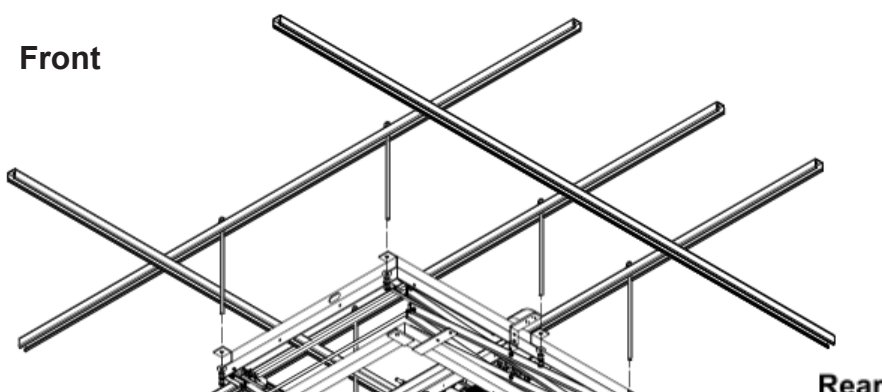

Install the Digital Controller

Attach the selected Digital Controller to the two vertical tabs at rear of the scissor lift's frame or relocate it to a more accessible service location.

Permanently install the Controller near its power source to the preferred mounting area, and within six feet of the Lift's connector panel, so that the motor's power cable and limit switch cables will reach the Digital Controller Box.

Connect the motor power cable to the Motor connector port of the Digital Controller.

Limit Switch Connector Panel

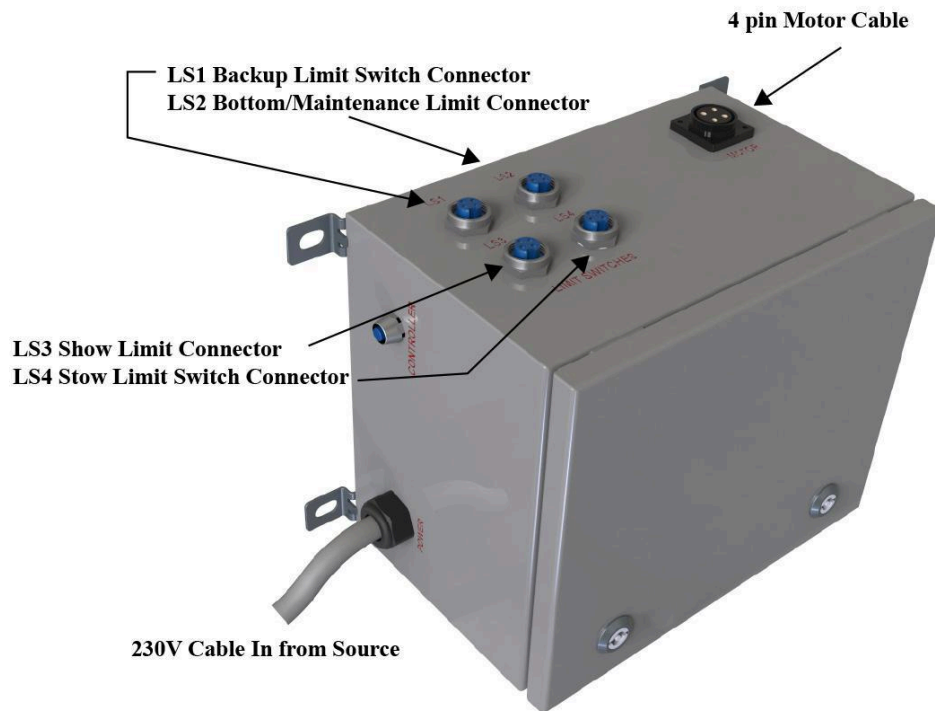

Install Remote Wall Switch Box

Locate a convenient area below the Lift, and at least six feet away from where it will be lowered too. Mount the Remote Wall Switch and connect the 30' Remote Wall Switch cable to its M12 connector. Connect the other end to the Digital Controller. Extension cables are available separately if needed. (see page 7)

Connect to a PL-SL-DEC Digital Controller.

Connect three 6' Limit Switch cables between the Digital Controller's LS1, LS2 & LS3 connector ports and the Lift's corresponding LS1, LS2, & LS3 connector port panel. (see Page 7)

Connect to a PL-SL-DEC3 and PL-SL-DEC+ Digital Controller.

Connect four 6' Limit Switch cables between the Digital Controller's LS1, LS2, LS3 & LS4 connector ports and the Lift's corresponding LS1, LS2, LS3 & LS4 connector port panel. (see Page 7)

PL-SL-DEC Remote Switch Box

Up / Down Switch

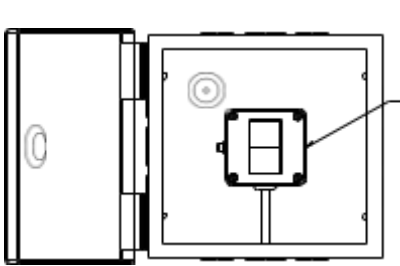

**Green Button = UP
Red Button = DOWN**

PL-SL-DEC3 & PL-SL-DEC+ Remote Switch Box

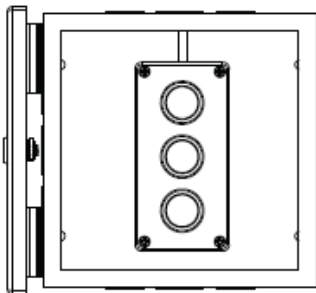

**Green Button = UP
Yellow Button = BYPASS
Red Button = DOWN**

Remove the Retraining Straps from the Scissor Lift now. The lower portion of the Lift should drop 1-2". If it appears that the Lift has not lowered 1-2", go to page 20 for trouble-shooting.

Connect the 30' long Remote Wall Switch cable connector to the DEC Digital Controller's M12 connector port. The other end will connect to the Remote Wall Switch Box.

Prepare Testing and Operating

Verify that there is sufficient vertical clearance below the lift and that objects and personnel below the Lift are cleared of the area before energizing and running the motor.

Before conducting lowering the Lift, check that the Lifting Cables are seated and tensioned correctly in the Wire Spool grooves and that the Lifting Cables and linkage are free of potential obstacles before testing the Lift.

Connect the 230V power from the facility's electrical panel to the DEC Digital Controller Box. Open the Controller box and flip the tandem circuit breaker switch to the up position. The internal LEDs will light up, indicating the power is on. **Allow two minutes for the system to boot up before operating.**

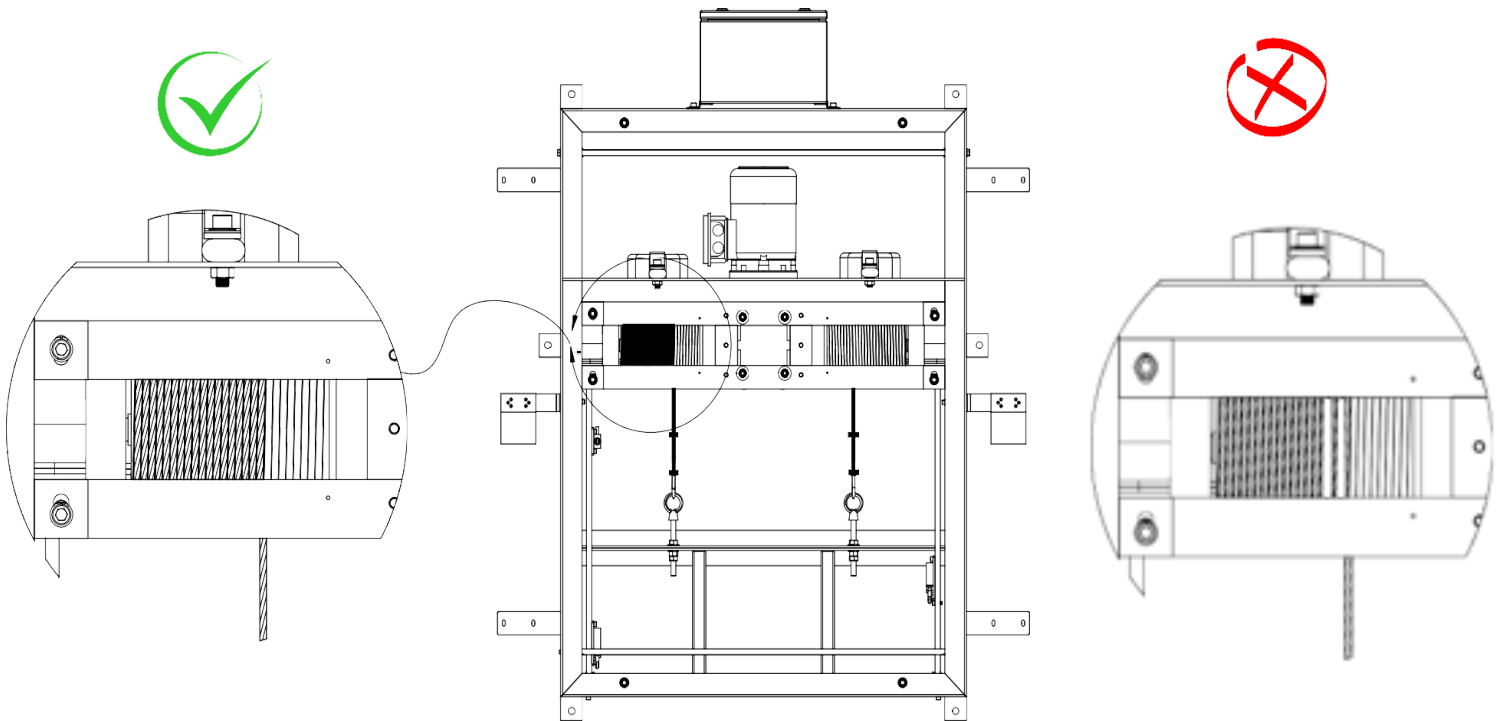

Lower the Lift one or two feet by pressing the Remote Wall Switch's red button. If the Lift responds, press the button again, briefly. This verifies that the lowering function is operational.

- If the Lift does not respond, check all the wire connections, and try again. If it still does not, refer to the trouble-shooting section on page 21.

Raise the Lift slightly by pressing the Remote Wall Switch's red button green button. Do not repeat. If the Lift is operating properly, go to the next step.

- If the Lift does not respond, check all the wire connections, and try again. If it still does not, refer to the trouble-shooting

section on page 21.

Identifying the Limit Switches

The positioning of the Scissor Lift is done via Limit Switches. Please refer below to identify the locations and purpose of the switches.

LS1 Backup Limit Switch
LS2 Bottom Limit Switch
LS1 Show/Top Limit Switch
LS1 Show Limit Switch
Note: The Forth Limit Switch is the Show Position Switch
for DEC3 and DEC+ Only

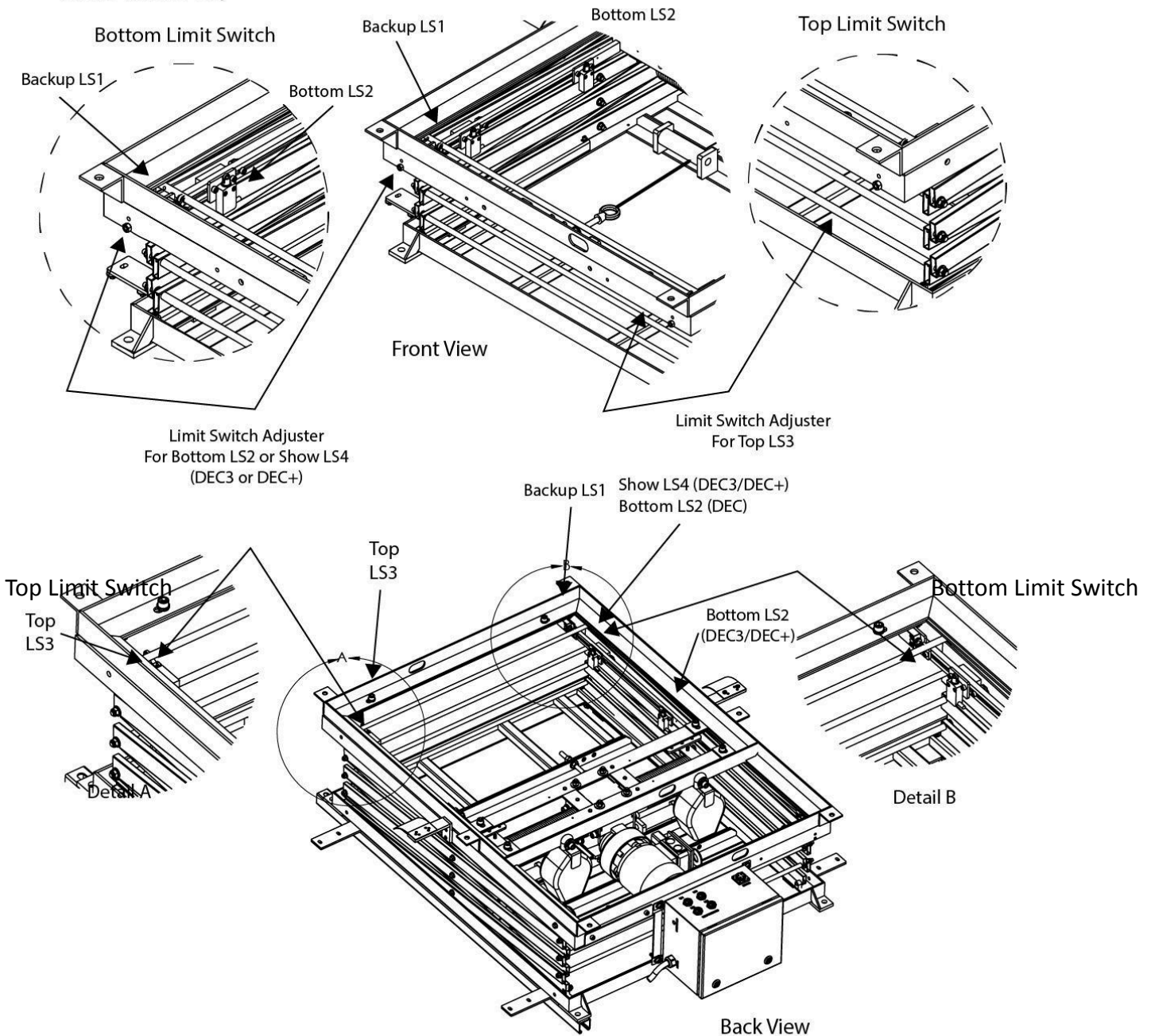

Limit Switch Adjustment Procedure

Refer Below for the property procedure in moving the limit switches Caution: small limit switch adjustments: Make small

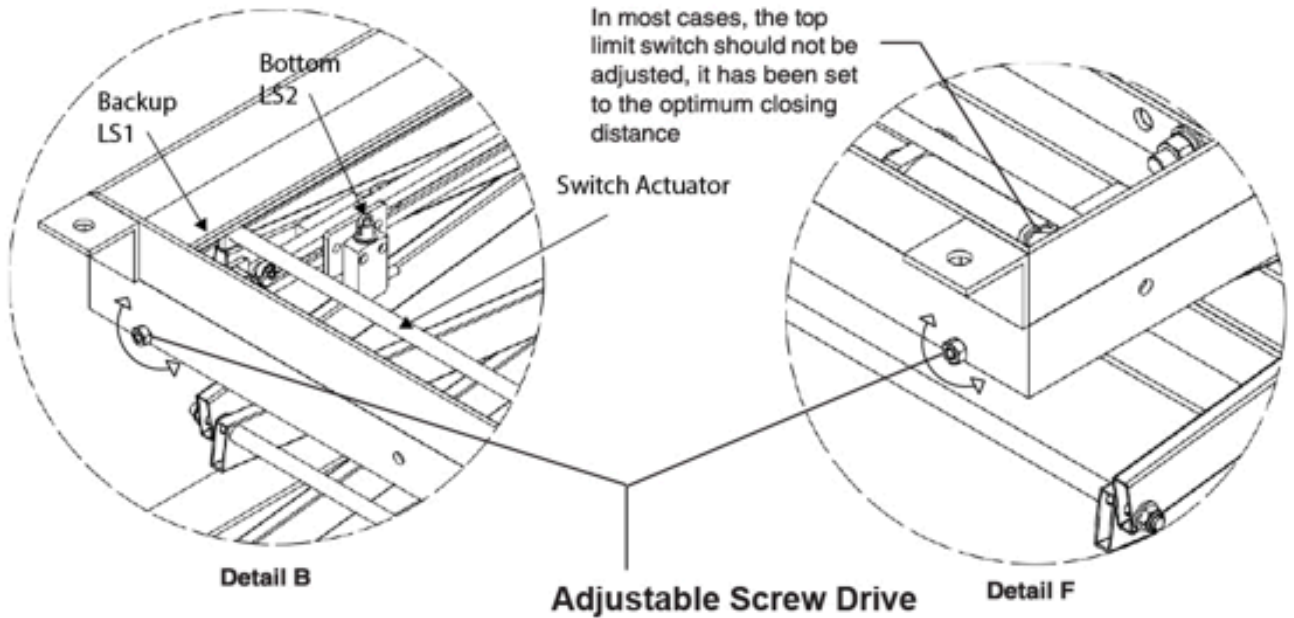

Lift position is set by turning these hex heads. Turning the Hex Head clockwise raises the Scissor Carriage height. Turning the Hex Head counterclockwise lowers the Scissors Carriage height limit. Once the desired positions are reached, re-tighten the two set screws permanently. See diagram F.

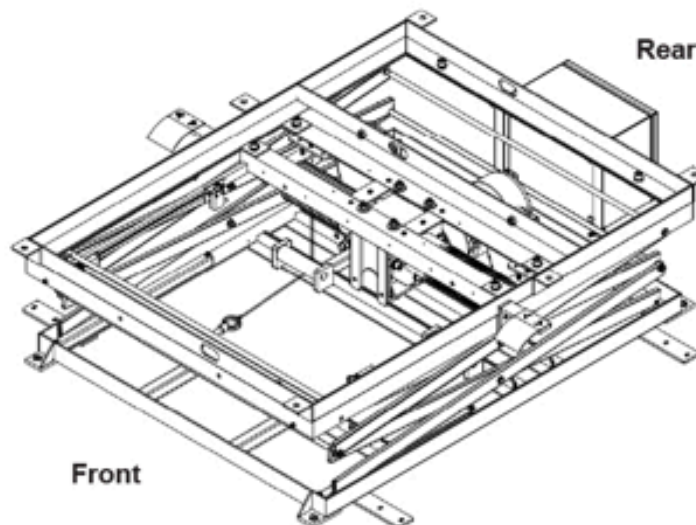
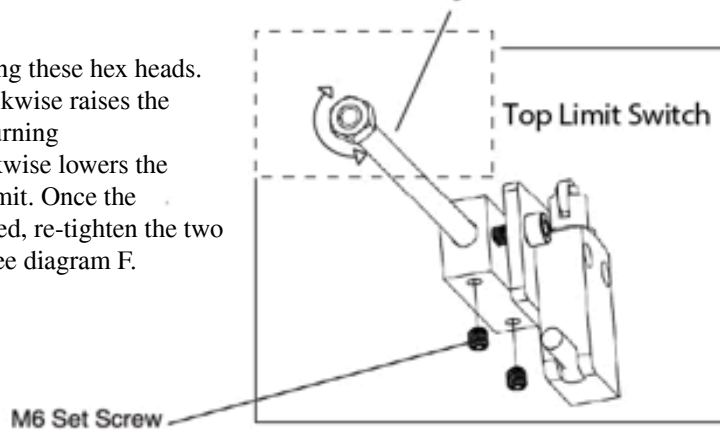

Set the Up & Down Limits of the Scissor Lift

Re-set the UP position (LS3) – The upper limit switch’s position is preset at the factory and must only be reset to a lower position (towards the motor). **Note: small adjustments make big changes to Scissor Lift height.**

To lower the Lift’s upper limit, loosen the LS3 switch’s side set screws, then rotate the LS2 Hex Head counterclockwise to lower the Lift’s upper limit. Repeat rotating back & forth until the desired height limit has been reached. Retighten the locking side set screws (See Page 10).

Test the newly set upper limit by pressing the Remote Wall switch’s red button to lower the Lift about 10-12”. Press the Switch’s green button to raise the Lift to its newly set upper position. The Lift will stop at its newly set height. **Note:** Avoid over-travel. Prepare to quickly release the button, if the Lift travels beyond its new upper limit.

Repeat these steps until the desired upper limit position has been reached. Retighten the locking side screws.

Reset the Down Position (LS2) - The lower limit switch’s position is preset at the factory and must only be reset to a higher position (See Page 10).

Lower the Lift to its factory preset maintenance position using the Remote Wall Switch’s red button. The lift will stop when it reaches this position.

To raise the Lift’s lower limit, loosen the locking side set screws of the LS2 Limit Switch, then rotate the Hex Head clockwise to raise the Lift higher. Repeat rotating back & forth until the Lower limit position has been set to the desired height. Retighten the locking side set screws (See Page 10).

SET THE SHOW & MAINTENANCE POSITIONS OF THE PL-SL-DEC3 & PL-SL-DEC+

+

Set the Show (middle) Position

Check that the fourth limit switch cable LS4 is connected to the Digital Controller and to the Scissor Lift’s connector panel. This fourth limit switch provides for a show (middle) position.

To find the precise show position, loosen the locking side screws of the LS4 Limit Switch, then rotate the Hex Head to adjust the limit switch, clockwise to raise, counterclockwise to lower. Repeat rotating back and forth until the show position has been reached. Retighten the locking side screws (See Page 10).

Set the Lower Maintenance Position (if needed)

Lower the Lift to its factory preset maintenance position using the Wall Switch’s red button. The lift will stop when it reaches this position.

Operating the Scissor Lift

To raise the Lift's lower limit, loosen the locking side set screws of the LS2 Limit Switch, then rotate the Hex Head clockwise to raise the Lift higher. Repeat rotating back & forth until the Lower limit position has been set to the desired height. Retighten the locking side set screws.

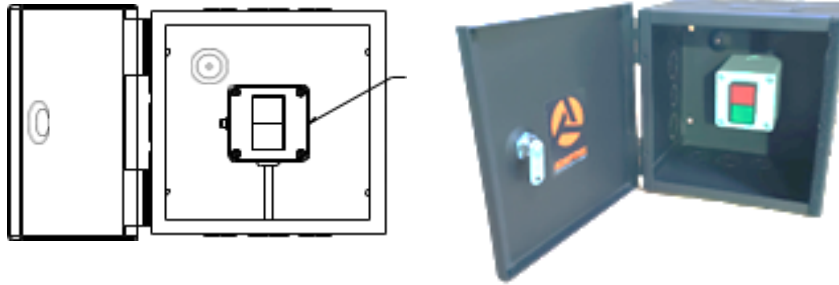

OPERATING THE SCISSOR LIFT WITH PL-SL-DEC

To raise the Scissor Lift, press the Remote Switch's green button until the Lift reaches the fully up position.
To lower the Scissor Lift, press the Remote Switch's red button until the Lift reaches the fully up position.

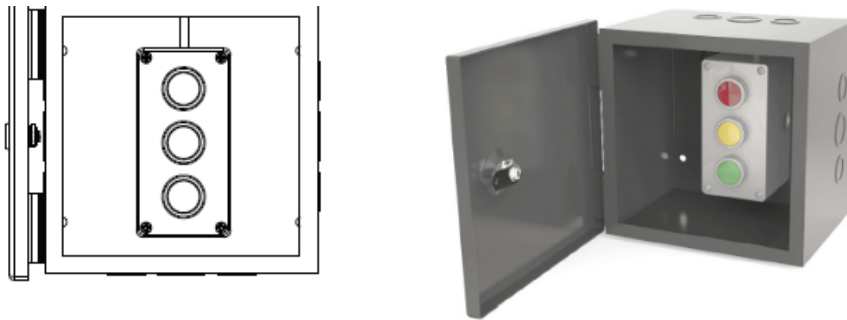

OPERATING THE SCISSOR LIFT WITH PL-SL-DEC3 and PL-SL-DEC+

To raise the Scissor Lift, press the Wall Switch's green button until it reaches the up (stowed) position.
To lower the Lift from the stowed position to the show position, press the Wall Switch's red button.
To lower the Lift further to the maintenance position, press and hold the Wall Switch's red & yellow buttons.
To raise the Lift from maintenance to the show position, press the Wall Switch's green button.
To raise the Lift from maintenance to the stowed position, press the Wall Switch's green & yellow buttons.

Install X-Y Projector Interface Option

Assemble and attach the X-Y interface to the projector first then lower the lift down to the X-Y interface and secure it to the lift.

After the full load is attached and free hanging, level the hanging assembly using the lift's lower frame cable nuts and eye bolts.

See installation instructions for the X-Y interface included in the kit.

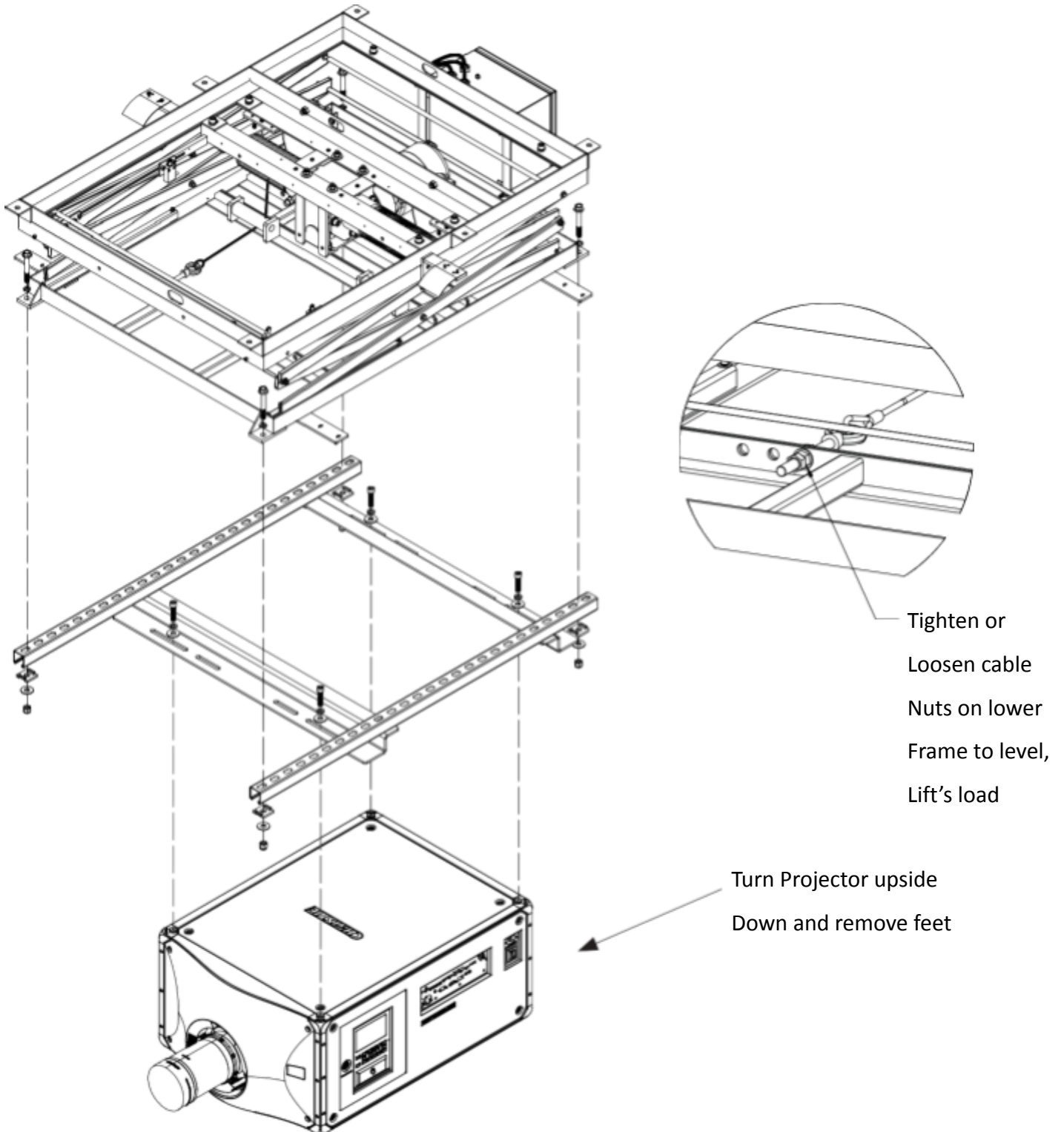

Install Projector Enclosure Option

Remove 4 pcs M12 bolts from the top of P-box enclosure. Lower lift onto the enclosure and line up the tabs of the lift's Docking Frame over the enclosure holes. Use M12 bolts to attach the enclosure.

Attach the P-BOX-15 (as shown below) or intended load. After the full load is attached and free hanging, level the hanging assembly using the nuts and eye bolts.

Run the lift up and down to verify proper operation.

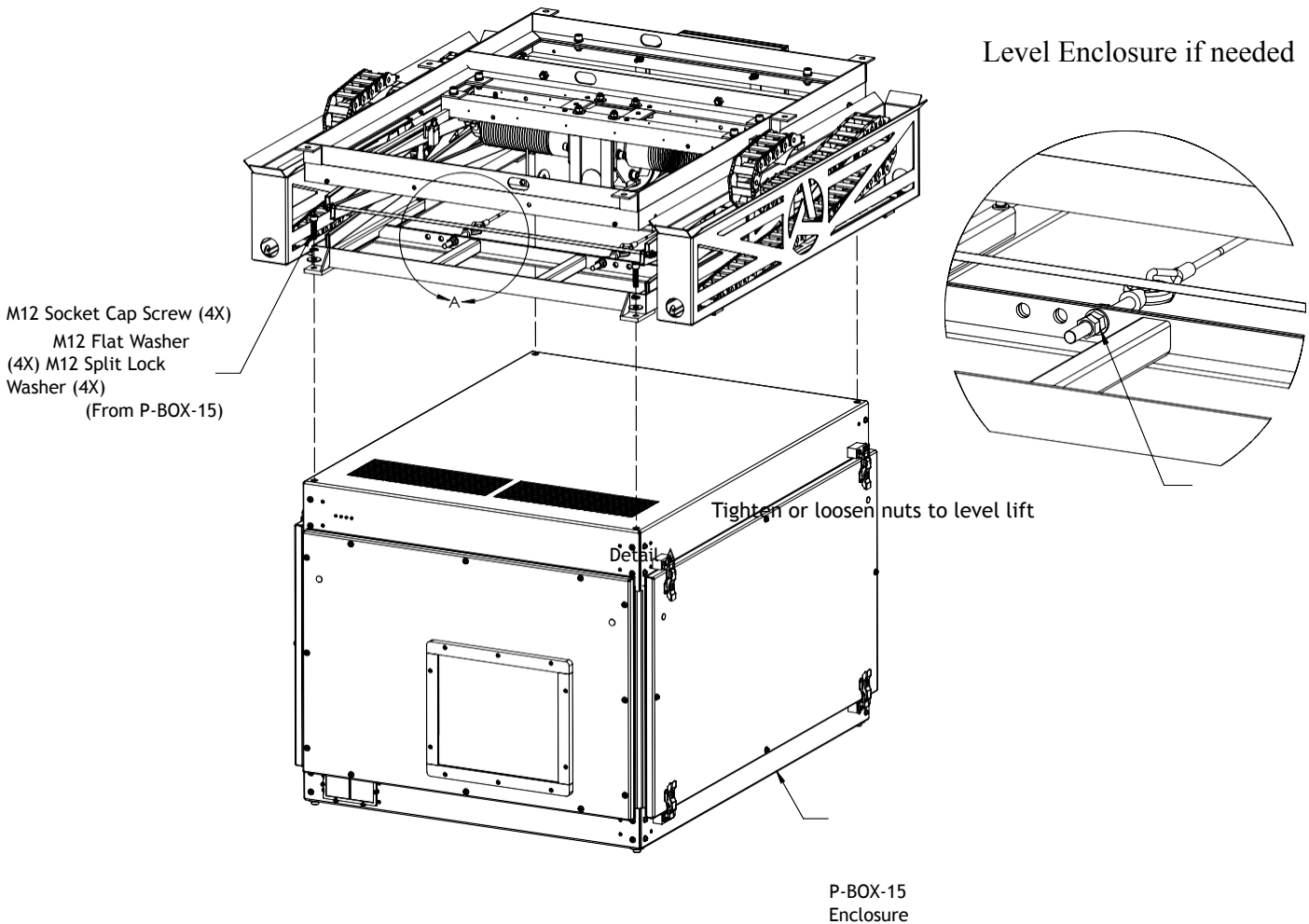

Install Side Cars & Wire Track

Assemble Side Cars to Scissor Lift using the supplied hardware.

Once the lift and projector and/or enclosure are secured to the lift, attach the cable side cars per the illustration below.

Attach the cable track to the inside of the side cars to the tabs located at the front (Detail A). Tighten supplied fasteners permanently. Insert and attach cable carriers to the top of the Lift per the illustration below (Detail B). Tighten supplied fasteners permanently.

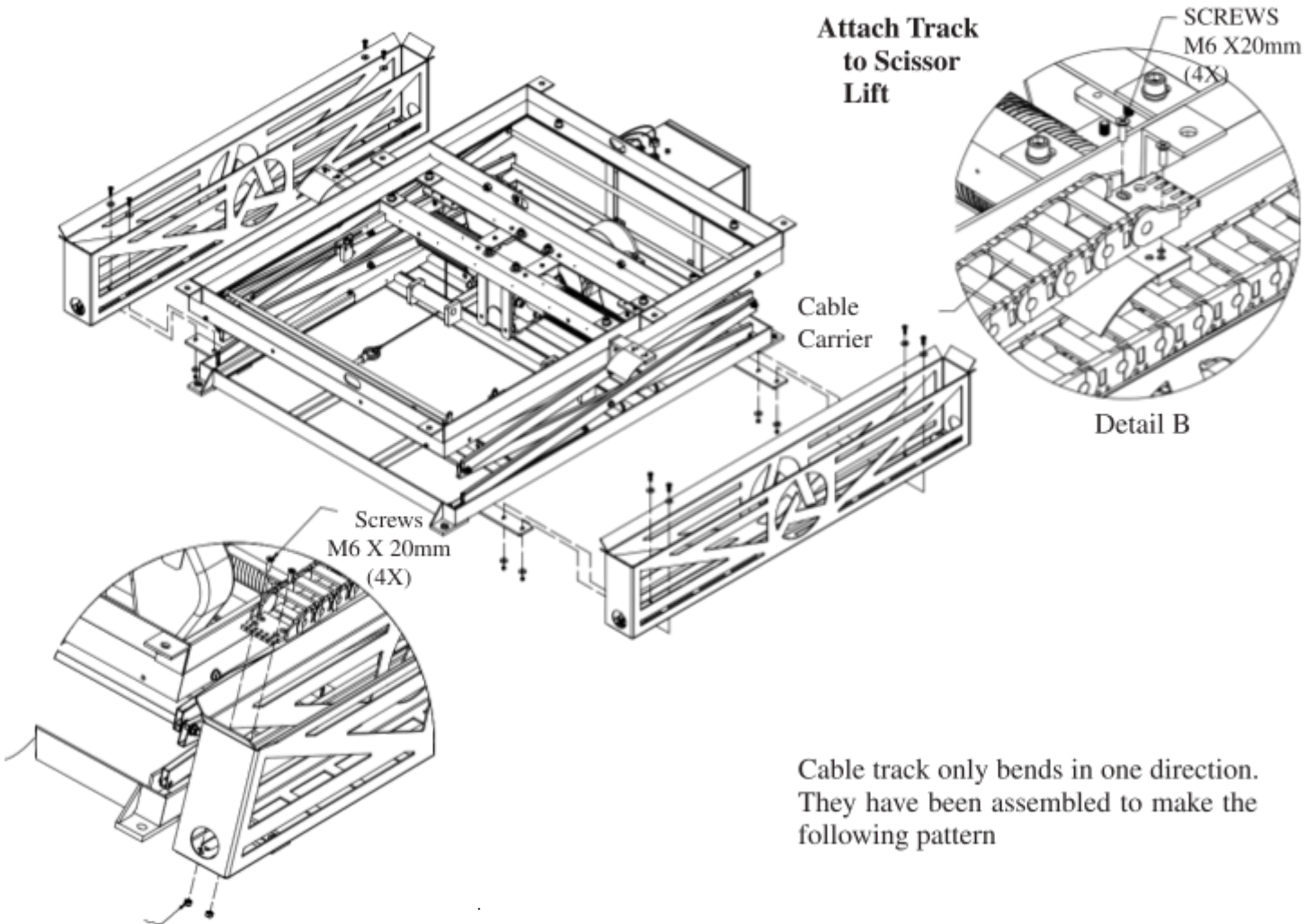

Cable track only bends in one direction. They have been assembled to make the following pattern

Nyloc Nut M6 (4X)

Detail A
Attach Track Inside Side Cars

Cable Track

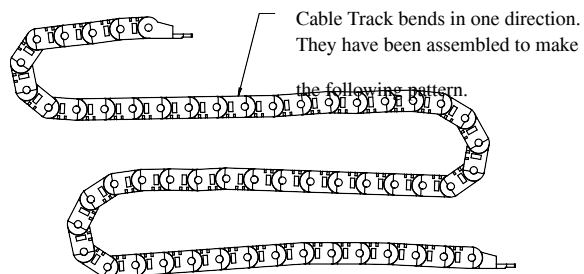

Annual Maintenance / Inspection

Regular maintenance & inspection will ensure the lift will always operate properly.

1) Wire rope cables

- a. Check that both wire rope cables seat in the Spooler grooves, are evenly tensioned and the lower portion of the Lift, projector and/or projector enclosure is level.
- b. Check Lifting Cables for debris, evidence of fraying or kinking.
- c. Check to see that the eye bolt nuts and turnbuckles of the lower frame are secured.
- d. Check that the Lifting Cable wire rope clips are secure & tight at the lower frame.

2) Limit switches

- a. Check that all four limit switches and their mounts are properly tightened down.
- b. Check limit switches for signs of wear and stop the Lift in the selected positions.
- c. Check that the wires leading to the limit switches are free from moving parts and wear.

3) Scissor arms

- a. Check for any chafing of the powder coat on any of the scissor links or cross brace rods. Any visible damage is an indication of mis-alignment of moving parts and must be repaired immediately.
- b. Check the fasteners at the ends of each of the linkage to be sure the hex nuts have not loosened.

4) Cable carrier (Tracks)

- a. Check that the cable tracks are unfolding and stowing properly and that they are still securing and protecting the cables.
- b. Look for any signs of wear or chafing of the wiring inside the track.

5) Lifting Cable Spooler

- a. Grease the bearing at end of drum annually.

6) Docking Frame and Lift chassis.

- a. Check that the Docking Frame hardware securing it to the overhead structure is tight.
- b. Check that the Lift Frame hardware securing it to the Docking Frame is tight.
- c. Check the integrity of the hardware that is securing the projector or projector enclosure.

Trouble Shooting

Please use the following as a quick reference guide. However, it is recommended that the factory be contacted when problems occur.

Scissor Lift linkage won't open.

The linkage is locked for shipping. Check that the restraining straps for shipping have been removed. If so, pull the Lift's lower frame down, sharply from the left and right sides of the Scissor assembly. The assembly should immediately drop down an inch or two.

The lift is jammed in the upper position.

If the motor makes noise but does not move, the upper LS3 limit switch has likely been compromised. Release tension to the scissor lift by loosening the lower frame's eyebolts. Press the Wall Switch's red button. If the Lift lowers, re-tighten the eyebolts then re-set the upper limit switch to a lower position (see page 12).

The Lift does not move when the buttons are pressed.

Check that the Wall Switch cable is connected to the Remote Wall Switch and to the Digital Controller. Open the Digital Controller Box door to check if power is being supplied. The LED display will read F60. Check that the pins inside the connectors are not bent.

The Lift is jammed in the lower position.

If the motor makes noise but does not move, the lower LS2 limit switch has likely been compromised. If limit switch is working, let the motor rest for ten seconds then try again. If it does not move, refer to page 21 – torque compensation

The Lift Load is not horizontal – Front to Back

The scissor lift is suspended by two left and right lifting cables, and the lift load is dependent on the load's center of gravity. This can be remedied by placing ballast inside of the enclosure, front or back, to level the load. Do not place ballast on top of the enclosure, or exceed the Lift's working load limit.

The Lift is not horizontal – Left to Right

The scissor lift is suspended by two left and right lifting cables. These cables are tensioned from the lower frame with turnbuckles that can be adjusted to level the load. Tightening the turnbuckle lifts one side and loosening one lowers the other side.

Power is connected, but the lift does not move

Tandem breakers are inside the Digital Controller Control that are toggled off for shipping. Check that the breakers are in the on/up position.

Lifting Cable is not Tensioned Properly:

Check the wire clips and make sure they are seated correctly on the eyebolt. Check scissors for obstructions. Same as above i.e.: jamming.

For any other issues, please contact the factory and a trained technician will guide you through the issues.

Digital Controller Schematic & Data

PL-SL-DEC & PL-SL-DEC3WIRE DIAGRAM
Digital Control Panel
(Door Removed for Clarity)

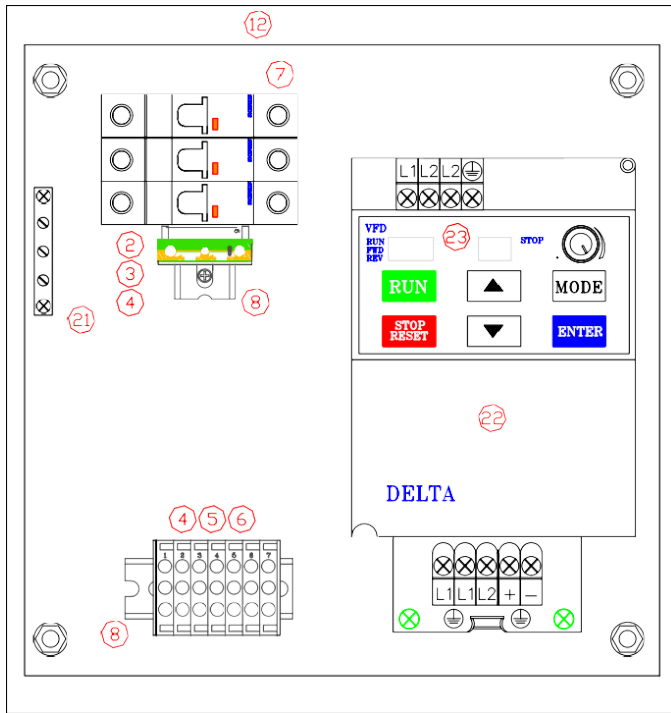

BILL OF MATERIALS		
ITEM	DESCRIPTION	QTY
①	STEEL ENCLOSURE, 8'X8"X6" WITH KDP/N	1
②	TERMINAL BLOCK, 1-CIRCUIT, GROUND, P/N MCC#7641K91	1
③	TERMINAL BLOCK, 1-CIRCUIT, END COVER, P/N MCC#7641K84	1
④	TERMINAL BLOCK, 1-CIRCUIT, P/N MCC#7641K51	1
⑤	TERMINAL BLOCK, 1-CIRCUIT, END COVER, P/N MCC#7641K33	1
⑥	TERMINAL BLOCK, END STOP, P/N MCC#7641K93	1
⑦	CIRCUIT BREAKER, 1-POLE, 10A, SIEMENS P/N 5SJ41107HG41	1
⑧	DIN RAIL 35mmX7.5mmX1m LONG, P/N MCC#8961K15	1
⑨	PUSH BUTTON UP/DOWN, GCX3150	1
⑩	CONTACT BLOCK P/N GCX1040-2	1
⑪	PUSH BUTTON ENCLOSURE, P/N SA103SL	1
⑫	STEEL ENCLOSURE, 12'X10'X8'	1
⑬	(13) BULKHEAD CONN. 4-PIN, MALE P/N 7231-13501-91=710100	1
⑭	IA CABLE #7000-12221-2141000, BULKHEAD 4-PIN, FEMALE	1
⑮	POWER CORD, 3-WIRE, 15', MCC#7081K23, <14-3 FOR POWER>	1
⑯	NEMA PLUG, L6-20 MCC# 7162K5	1
⑰	CORD GRIP .5"-71CORD, 3/4 KNOCK DUT SIZE MCCH 69915K55	1
⑱	7/8 FEMALE PIGTAIL CONNECTOR	4
⑲	PUSH BUTTON, MIMENTARY <20-PACK, EINLY 1 NEEDED>	1
⑳	CORD GRIP .5"-71' CORD, 3/4 KNOCK DUT SIZE MCCH 69915K55	1
㉑	GROUNDING BLOCK, LINEAR, 2.25' LONG	1
㉒	VARIABLE FREQUENCY DRIVE, DELTA P/N VFDOO7EZIA	1
㉓	VARIABLE FREQUENCY DRIVE, KEYPAD, DELTA P/N KPE-LE02	1

Electrical Requirements:

The Main Control Panel requires a dedicated 230 Volt single phase 20-amp circuit. Included is a pre-wired cord with an L6-30P NEMA plug. This Panel can also be wired directly to breaker switch if preferred.

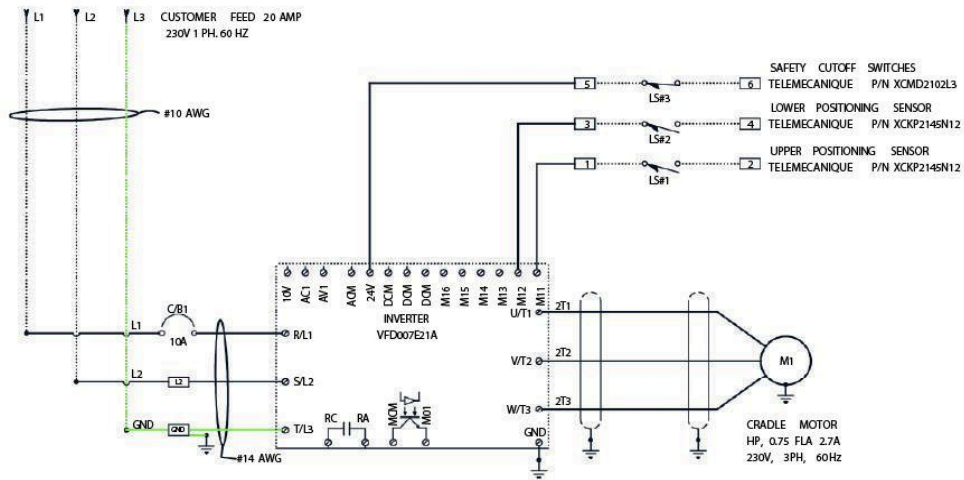

Instructions for Parameterizing Delta Drives

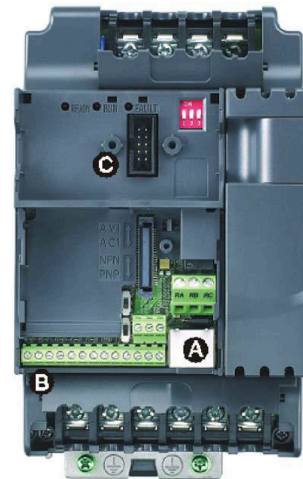

- Press the "MODE" button on the front of screen repeatedly until the following shows on the screen: "10.00"
- Press enter, the screen should now display "00". Press the "Up" button to change this value to "01"
- Press enter again and the screen should now show the parameter numbers. (i.e. "10.00") You can access the various parameters you wish to change by pressing the "Up/Down" buttons and pressing enter. Set the desired values for each parameter and press enter. (Refer to the next page for a list of parameters)
- Pressing the "Mode" button will take you out of the parameter settings.
- Press the "Mode" key until the screen shows the letter F followed by a three-digit value such as "F45.0". Rotate the knob on the right until this value reads "F80.0"

*If the Wall-Lift fails to move, check to see if the Drive has been set to PNP mode. Refer to the picture below.

Rev.01 - Added Parameters for Scissor Lift - 11/12/19
 Rev.02 - Added Torque Compensation Detail - 02/12/20

Parameter	Value	Description
1.02	230.00	Maximum voltage frequency