

PIPE-500-1422

200 lb WLL

1/2" DIA. OVERHEAD TELESCOPING PIPE EXTENDER

XTENDER™



The PIPE-500-1422 offers installers the ability to lower and raise items that are suspended from above. This Adjustable Pipe offers 12 different extensions in increments of 3/4" between 14" and 22".

Adaptives PIPE-500-SERIES works with a variety of our overhead mounting products such as our Unistrut mounting product line as well as wood and metal beam clamps.



Strut Mounted

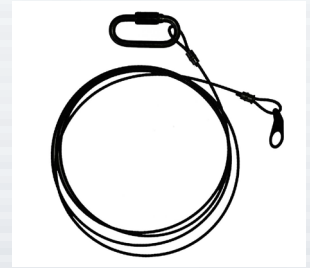

Safety Cable Included

STANDARD FEATURES:

- ▶ Telescoping pipe offers a range of extensions
- ▶ Adapts to multiple overhead mounts.

OPTIONAL ACCESSORIES:

- ▶ Ceiling Mounts - See Datasheets
- ▶ Pipe Extensions - See Datasheets
- ▶ MP-500NPT-TA Strut Mount
- ▶ MP-500NPT-CP Ceiling Mount
- ▶ MP-500NPT-GSA Gimbal Mount
- ▶ UB-MT-500NPT Lower Mount
- ▶ UB-3RDX-60 3-Axis Speaker Mount

SPECIFICATIONS:

Outer Tube: Structural Steel Tube
Inner Tube: Structural Steel Pipe
Finish: Powder Coat
Color: Black
WLL: 200 lb. (90.7 kg) max.
Vertical Orientation Only
Design Factor: 7:1 ratio

PACKAGE CONTENTS:

1pc Telescoping Pipe
1pack Hardware Kit



MADE IN USA

Rated for indoor use.

DIMENSIONS:

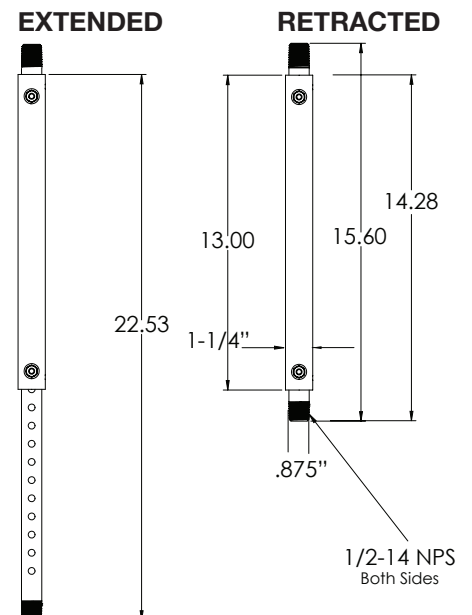

Strut Mount

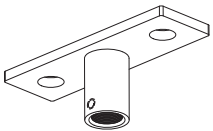

Ceiling Mount

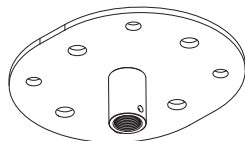

3-Axis Speaker Mount

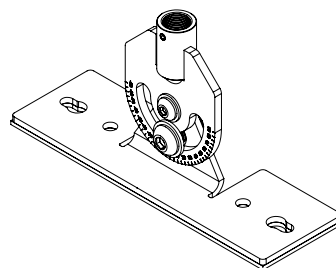

Gimbal Mount

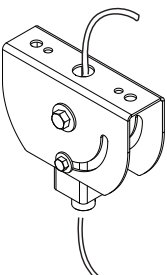

Lower Mount

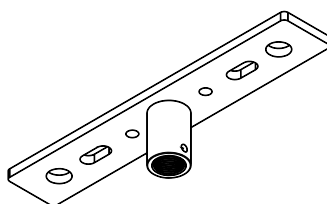

Adaptive Technologies Group

1635 E. Burnett Street | Signal Hill, CA 90755 USA
Ph: 562.424.1100 | Fax: 562.424.3520
www.adaptivetechgroup.com



ALWAYS INSTALL SAFETY CABLES

WARNING: Mounting and/or suspension of equipment requires experienced professionals. Improperly installed equipment can result in property damage, personal injury and/or liability to the installing contractor.