

The FP-MK2-3X1 planar array kit gives designers, contractors and audio consultants the ability to join three EAW MK2 series speakers in a tight pack or up to 60° splayed configurations. The FP-MK2-3X1 Kit allows the speaker cabinets to be adjusted relative to each other to achieve the optimum sound directivity. A series of holes with angle indicator marks are provided to easily adjust the splay angle from tight pack to 60° at an increment of 2.5° between speakers.

**Installing speakers must be performed by experienced professionals.** If in doubt about the integrity of the structure you are mounting or suspending to or not sure about the proper hardware or method to use, consult a certified rigging company.

**Package contents:**

- 2 pcs 7-3145 Joiner Plate
- 2 pcs Eyebolt, 3/8-16x2.5
- 1 pcs Eyebolt, 3/8-16x1.25
- 10 pcs Button head socket screw, 3/8-16x1.5
- 13 pcs Flat washer, 3/8

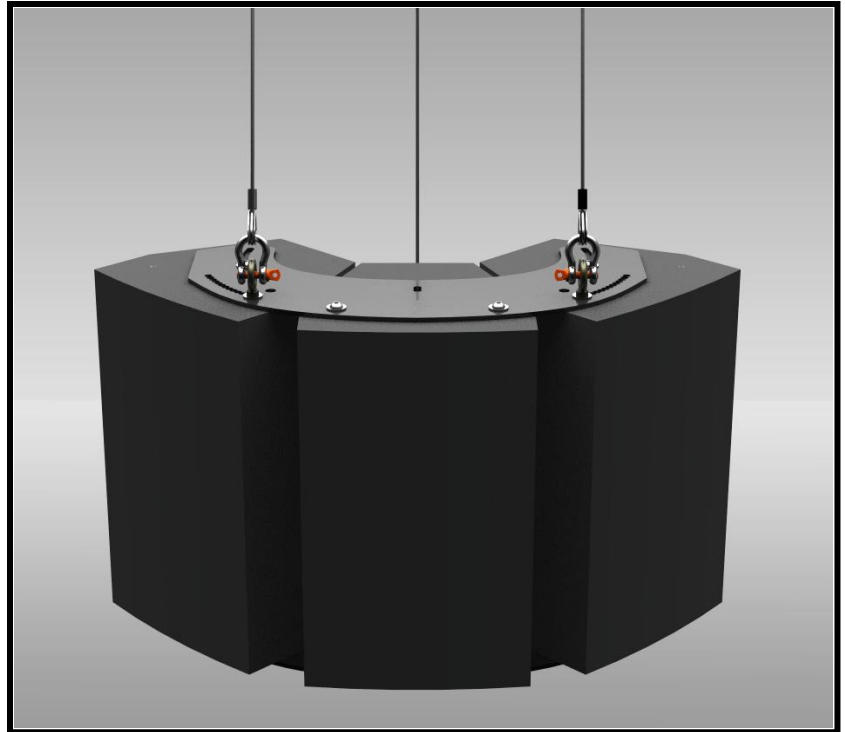

**CAUTION: PLEASE READ CAREFULLY BEFORE PROCEEDING**

Due to the wide variety of building structures, materials and suspension methods, the installing contractor/installer will use good judgment in selecting the proper mounting area and hardware. As a guide, the installation, when complete, should be capable of supporting at least 5 times the actual load. Follow building code requirements to safely suspend the speakers to the building structure

**Step 1.**

Remove and discard the screws from the top and bottom of the speaker that will be used for attaching the joiner plate.

**Step 2.**

Flip the speakers so that the bottoms are facing up. Position the speakers side by side. Determine the desired splay angle between speakers (Figure 1.) Attach joiner plate to the bottom side of the speakers from the selected splay angle hole using supplied 3/8" screws and flat washers (Figure 2.) Do not permanently tighten until all plates are installed.



Figure 1

**Step 3:**

Slowly flip the speakers so the top is facing up. Attach the other joiner plate to the top of the center speaker first using the supplied 3/8" screws. Attach the joiner plate to the side speaker's inner rigging points and joiner plates slot using the 3/8" screws and flat washers. Install the 3/8-16x2.5" long eyebolts and flat washers using the same holes as the bottom joiner plate (Figure 2.)

**Step 4:**

Install one 3/8-16x1.25" long eyebolts and flat washer to the lower back of the center speaker for pull back attachment (Figure 2.)

**Step 5:**

Tighten bolts and eyebolts permanently.

**Step 6:**

Use the eyebolts on top of the speakers for primary suspension points (Figure 3). Use the rear eyebolt for the pull back point to adjust the tilt angle of the cluster (Figure 4.)

**Step 7:**

Check all hardware connections before hoisting cluster.

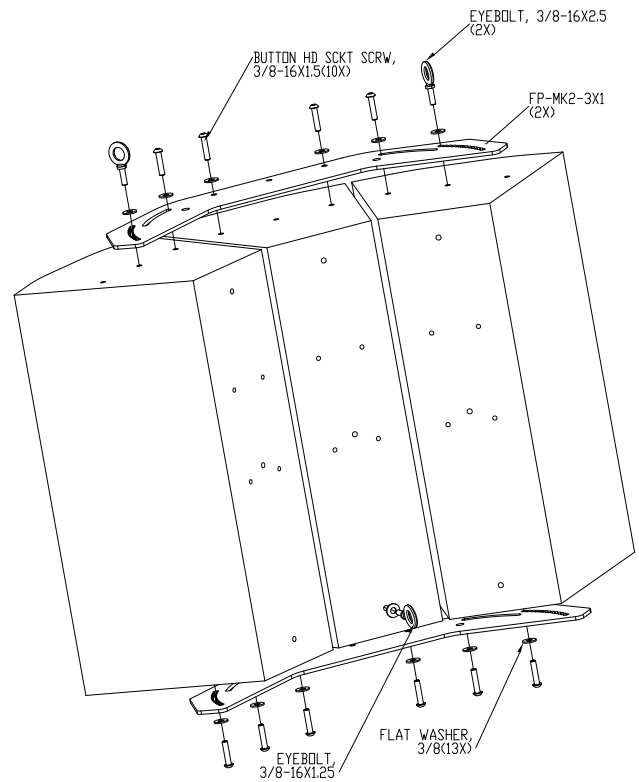

Figure 2

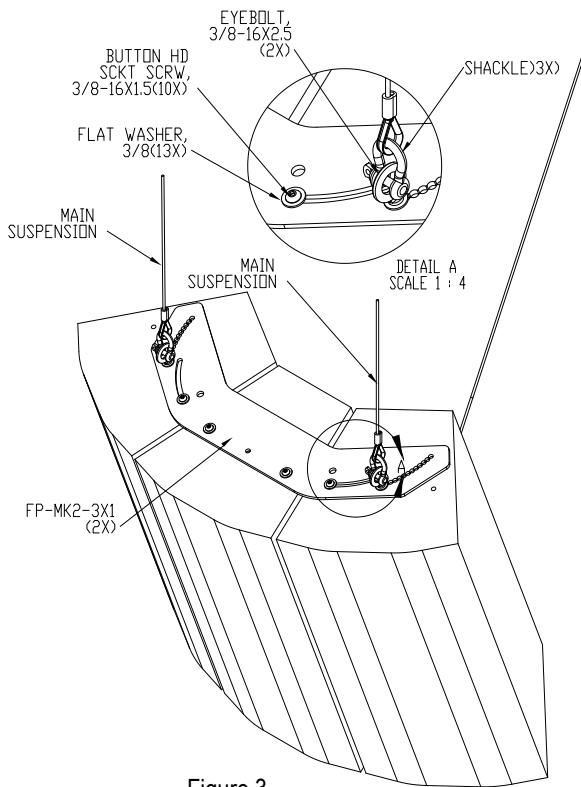

Figure 3

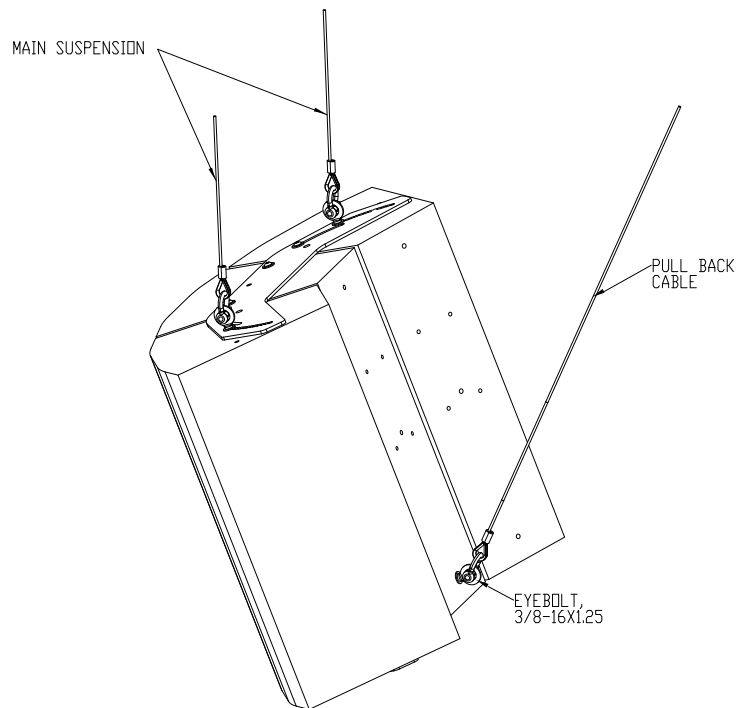

Figure 4