

## 3 WIDE X 1 DEEP PLANAR ARRAY CONFIGURATION

The FP-PD5200-3X1 planar array kit gives designers, contractors and audio consultants the ability to create three PD5200 or PD5212 series speakers in a tight pack or splayed configurations. The FP-PD5200-3x1 kit provides a method of flying a planar or line array configuration while offering the capability of allowing cabinet's splay angle to be adjusted relative to each other to find the optimum sound directivity. A series of holes are provided to easily adjust the splay or tilt angle from 30° to 60° at an increment of 2.5° between speakers.

**Installing speakers must be performed by experienced professionals.** If in doubt about the integrity of the structure you are mounting or suspending to or not sure about the proper hardware or method to use, consult a certified rigging company.

### Package contents:

- 4 pcs Joiner Plate
- 16 pcs Button head screw, M10x45mm long
- 16 pcs Split lock washer, M10
- 16 pcs Flat washer, M10
- 2 pcs Eyebolt, M10 x 50mm Long
- 2 pcs Eyebolt, M10x 35mm long
- 1 pc Instruction Sheet

### **CAUTION: PLEASE READ CAREFULLY BEFORE PROCEEDING**

Due to the wide variety of building structures, materials and suspension methods, these instructions assume that the installing contractor/installer will exercise good judgment in selecting the proper mounting area and hardware. As a guide, the installation, when complete, should be capable of supporting at least 5 times the actual load. Follow building code requirements to safely suspend the speakers to the building structure

### **3 WIDE X 1 DEEP PLANAR ARRAY:**

#### Step 1:

Flip the three speakers so that the bottoms are facing up and lay them side by side. Unscrew existing speaker screws where the joiner plate will be installed. Discard removed screws.

#### Step 2:

Decide the splay angles of the loudspeaker cluster (Figure 1). Install the joiner plate on the speakers using the appropriate holes for the desired loudspeaker splay angles. Use the provided M10 screws, flat washers and split washers. Do not tighten bolts until all joiner plates are installed (Figure 2).

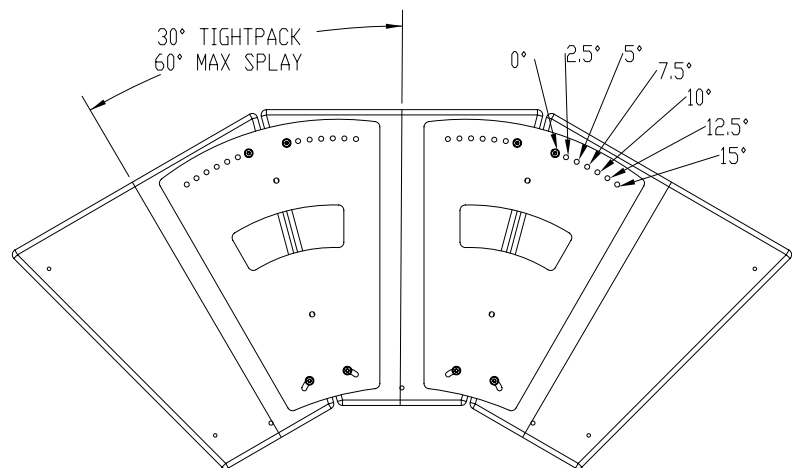

Figure 1

**Step 3:**

Carefully flip the three speakers together so that the top is facing up. Removed the screws in the holes where the joiner plates are installed. Install the joiner plates using the same holes as the bottom joiner plates using the provided screw, split washer and flat washer (Figure 3).

**Step 4:**

Install the M10x 50mm long eyebolts with flat washers on the inner front holes of the side speaker (Figure 3).

**Step 5:**

Install the M10 x 35mm long eyebolt on the rear of the center speaker for single pull back point (Figure 3). For a dual pull back point, install the M10x35 eyebolt on the rear of the side speakers (Figure 3).

**Step 6:**

When all joiner plates are installed, tighten screws permanently.

**Step 7:**

Attach a load rated suspension cables or chains on the top front eyebolts. Use the rear eyebolt for pull back points and to adjust the tilt angle of the loudspeaker cluster assembly as shown in the main illustration (Figure 4).

**Step 8:**

Check all hardware connections before hoisting cluster.

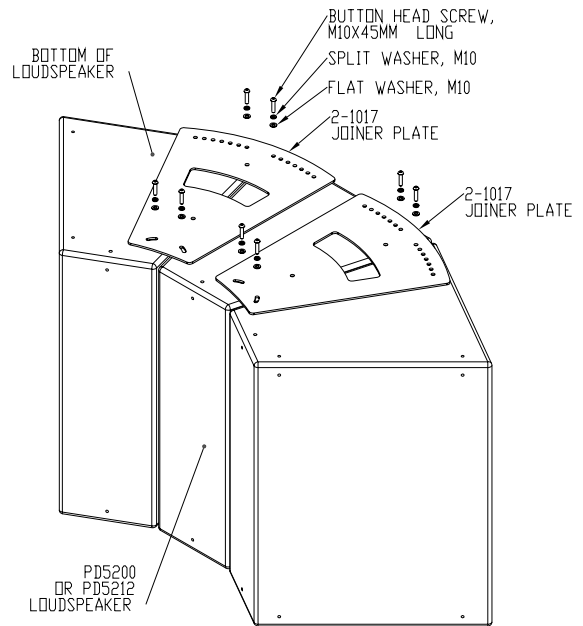

Figure 2

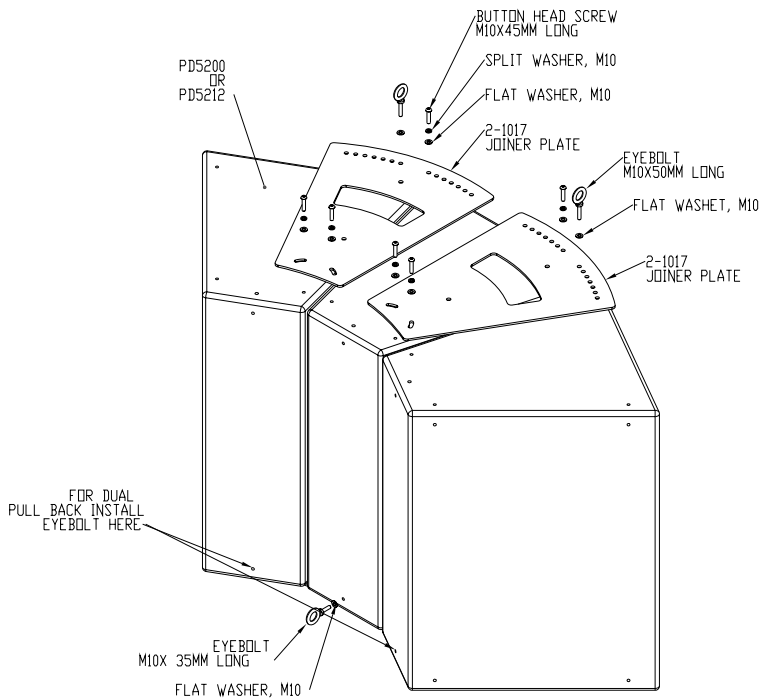

Figure 3

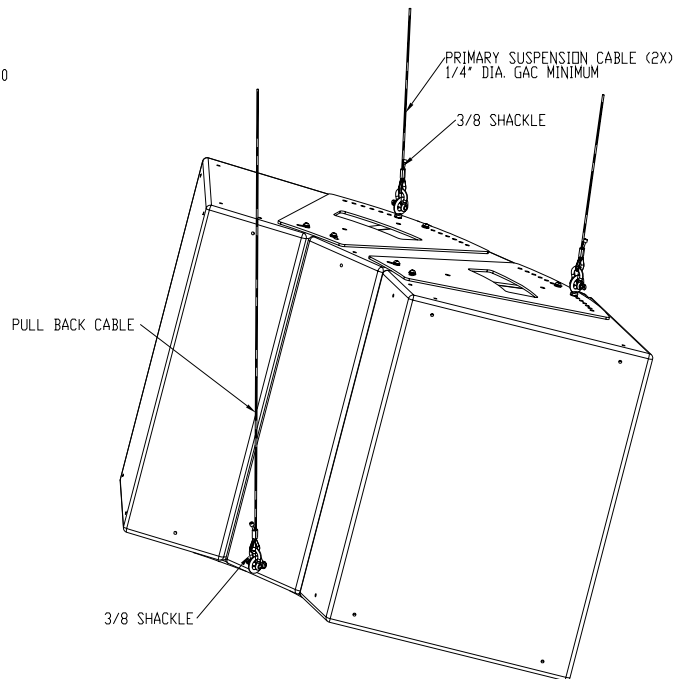

Figure 4

### 1 WIDE X 3 DEEP LINE ARRAY- HORIZONTAL

Step 1-3 From 3 WIDE X 1 DEEP PLANAR ARRAY Installation Instruction:

**Step 4:**

Carefully flip the three speakers together so that the top is facing up. Removed the screws in the holes where the joiner plates are installed. Install the joiner plates using the same holes as the bottom joiner plates using the provided screw, split washer and flat washer.

**Step 5:**

When all plates are in position, tighten all screws permanently

**Step 6:**

Remove and discard the screw on the side of the designated upper speaker. Install the M10x 50mm long eyebolts on the side holes of the designated upper loudspeaker using flat washers (Figure 5).

**Step 7:**

Install the M10x 35mm long eyebolt on the both the rear rigging holes of the lowest speaker (Figure 5).

**Step 8:**

Attach a load rated suspension cables or chains to the top eyebolts of the upper loudspeaker. Use the eyebolt on the lowest speaker for pull back points and to adjust the tilt angle of the loudspeaker speaker cluster assembly as shown in the main illustration.

**Note:**

*Pull back can be individual cable per speaker or can be bridled to a single point as shown in the 1 WIDE X 3 DEEP LINE ARRAY main illustration.*

**Step 9:**

Check all hardware connections before hoisting cluster.

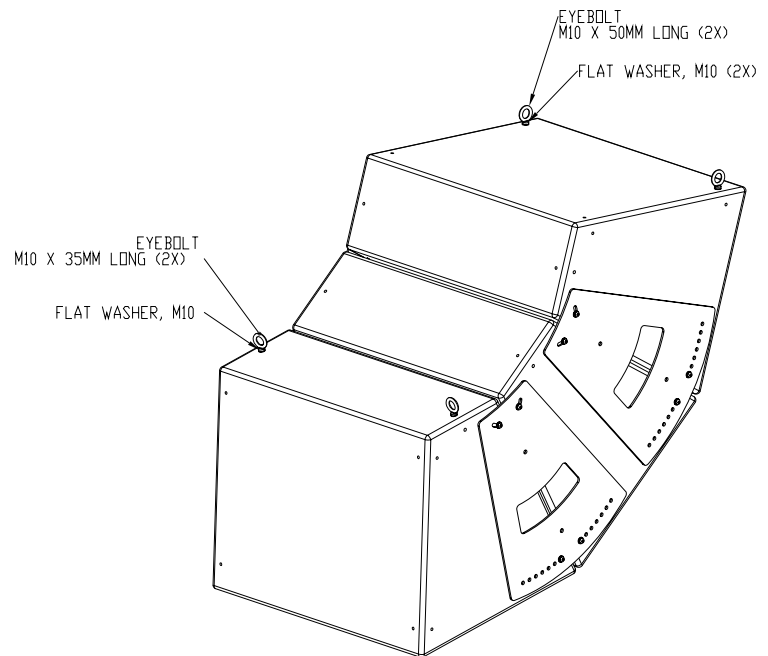

Figure 5