

LTMB24 1X3

BOSE SUB ARRAY KIT

SUB ARRAY RIG



Unique attributes of the Bose MB24 low frequency sub woofer require specific interdependent physical relationships when arraying these cabinets together. ATM Fly-Ware's LTMB24 overhead truss system is an efficient light-weight suspension frame that places these cabinets into their acoustically correct horizontal position and allows them to be aimed and suspended as one structure, two-wide, quickly and easily.

In addition to being secured into the MB24 threaded fittings, the LTMB24 overhead truss system comes with threaded compression rods that secure it to a second frame. Additional frames and compression rods allow for more tiers, vertically, up to four cabinets deep, forming an eight piece sub array. Each frame is equipped with load rated rigging points and accommodations for multiple tiered compression rods.

To add additional tiers, order the LTMB24-ROD-KT, two kits per tier, maximum of four tiers.

3 SPEAKERS - BOSE MB24

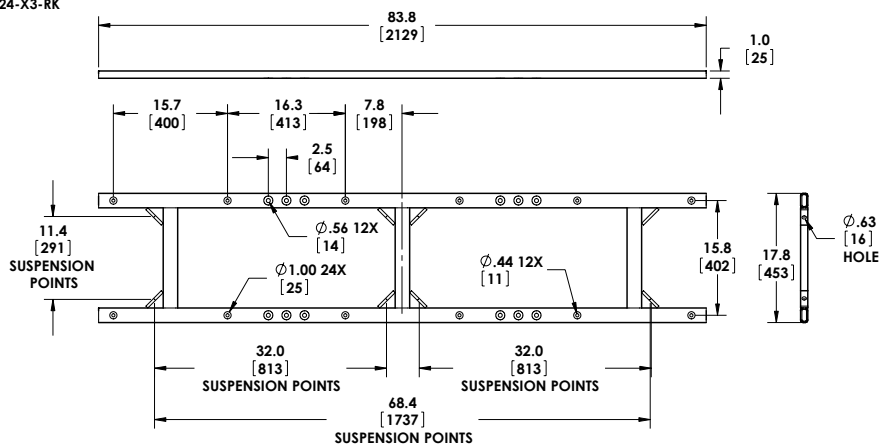
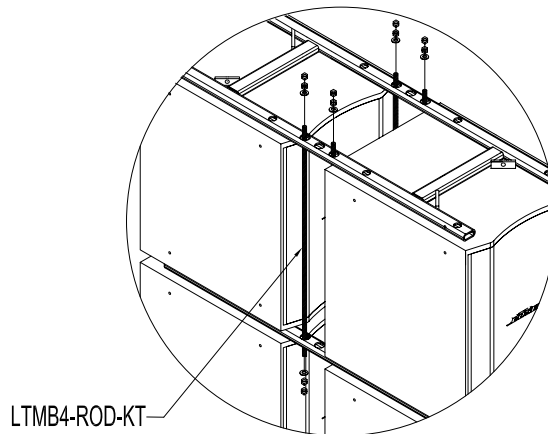
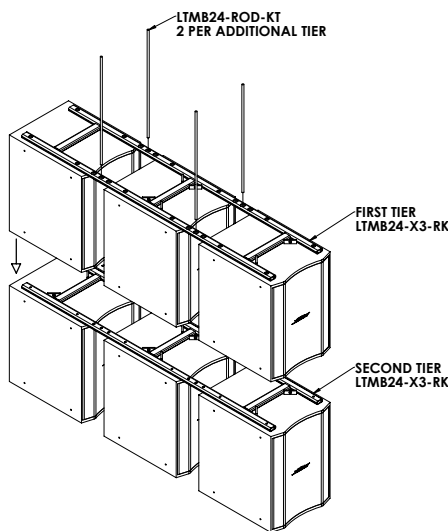

Rated for indoor use.

ALWAYS INSTALL SAFETY CABLES

WARNING: Mounting and/or suspension of audio and video equipment requires experienced professionals. Improperly installed loudspeakers can result in property damage, personal injury and/or liability to the installing contractor.