

8 7 6 5 4 3 2 1

D  
C  
B  
A

D  
C  
B  
A

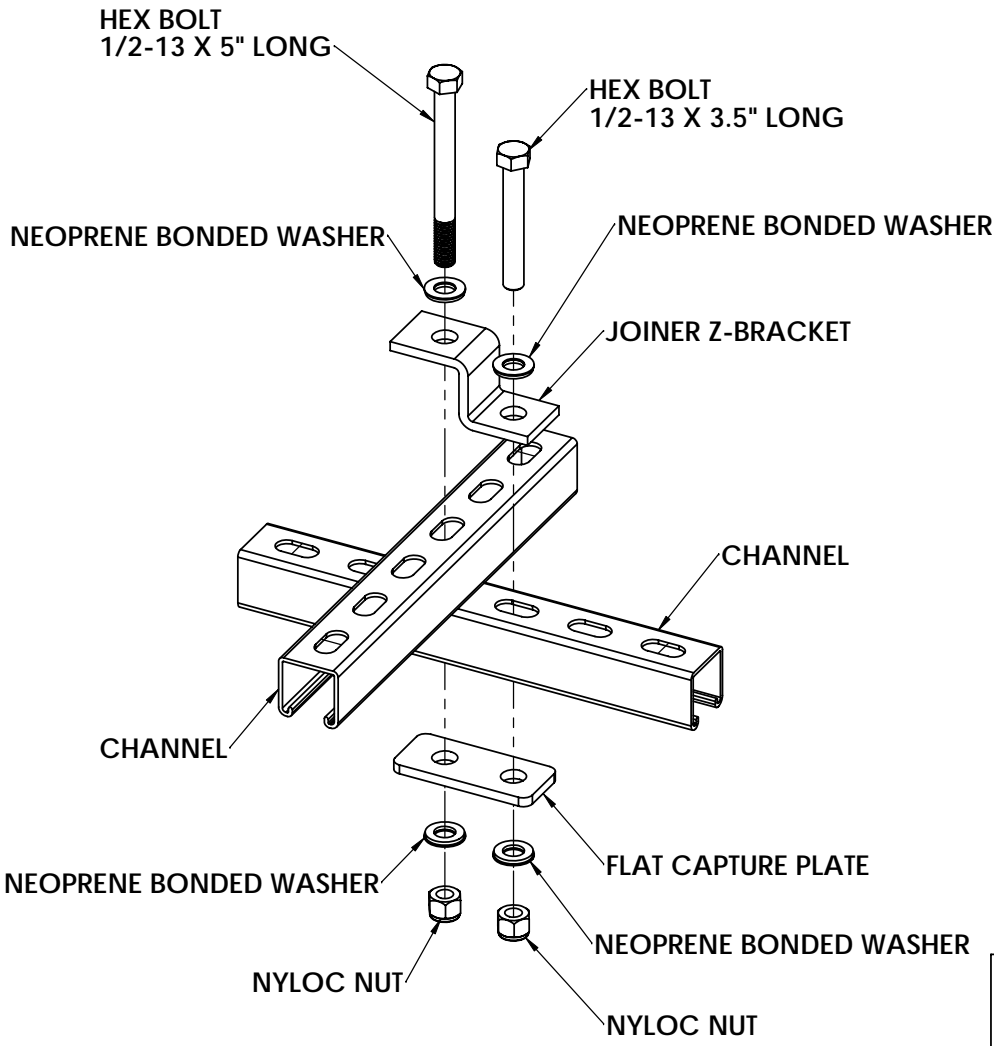

**ASSEMBLY INSTRUCTION:**

1. PLACE Z-BRACKET ON TOP OF THE TWO CROSSING CHANNELS.
2. PLACE THE NEOPRENE BONDED WASHERS OVER THE HOLES WITH THE RUBBER ON THE Z-BRACKET THEN INSERT 5" LONG BOLT AND THE 3.5" LONG BOLT THROUGH THE HOLES OF THE Z-BRACKET.
3. PLACE THE FLAT CAPTURE PLATE UNDER THE BOTTOM CHANNEL , ALIGN THE HOLES TO THE BOLTS AND SECURE USING THE NEOPRENE BONDED WASHERS AND NYLOC NUTS.
4. POSITION CHANNELS THEN TIGHTEN BOLTS AND NUTS. DO NOT OVER TIGHTEN SO THAT IT WILL NOT CRUSH THE CHANNELS.

REVISIONS					
ZONE	REV.	DESCRIPTION	DRAWN	DATE	APPROVED

FILE LOCATION:

<b>PROPRIETARY AND CONFIDENTIAL</b> THIS DRAWING IS THE PROPERTY OF ADAPTIVE TECHNOLOGIES GROUP AND EMBODIES A PROPRIETY DESIGN ORIGINATED BY ADAPTIVE TECHNOLOGIES GROUP ALL DESIGN, MANUFACTURE, REPRODUCTION, USE AND SALE RIGHTS REGARDING THE SAME ARE EXPRESSLY RESERVED. THIS DRAWING MAY NOT BE REPRODUCED OR INFORMATION HEREIN TRANSMITTED IN ANY WAY WITHOUT WRITTEN CONSENT FROM ADAPTIVE TECHNOLOGIES GROUP ALL PATENT RIGHTS HERETO ARE EXPRESSLY RESERVED BY ALLEN PRODUCTS CO. SIGNAL HILL, CALIFORNIA	UNLESS OTHERWISE SPECIFIED:	NAME	DATE	 <b>ADAPTIVE TECHNOLOGIES GROUP</b> 1635 E. Burnett Street Signal Hill, CA 90755 Tel: 562-424-1100 Fax: 562-424-3520	
	DIMENSIONS ARE IN INCHES TOLERANCES: FRACTIONAL ± 1/64 ANGULAR: MACH ± .5° TWO PLACE DECIMAL ± .03 THREE PLACE DECIMAL ± .01	DRAWN	TBA		10/24/13
	INTERPRET GEOMETRIC TOLERANCING PER:	CHECKED			TITLE: <b>CG-P1045-ZB ASSEMBLY INSTRUCTION</b>
	MATERIAL	ENG APPR.			MFG APPR.
FINISH	Q.A.			NEXT ASSY:	
DO NOT SCALE DRAWING	COMMENTS:			USED ON:	
				SIZE <b>B</b>	
				DWG. NO. <b>CG-P1045-ZB</b>	
				REV <b>00</b>	
				SCALE: 1:3	
				WEIGHT:	
				SHEET 1 OF 1	

8 7 6 5 4 3 2 1