

The FP-AM4212-2X1 planar array kit gives designers, contractors and audio consultants the ability to create a two JBL AM4212, AM5212, AM6212 or AM7212 series speakers in a tight pack configurations. The FasPac™ provides a method of flying a tight pack array while offering the capability of allowing cabinets to be adjusted relative to each other to find the optimum sound directivity. A series of holes are provided to easily adjust the splay angle from 0° to 30° at an increment of 2.5 degree.

Installing speakers must be performed by experienced professionals. If in doubt about the integrity of the structure you are mounting or suspending to or not sure about the proper hardware or method to use, consult a certified rigging company.

Package contents:

- 4 pcs Front-Rear Joiner Plate
- 8 pcs Button head sckt screw, M10 x 45mm long
- 12 pcs M10 flat washers

CAUTION: PLEASE READ CAREFULLY BEFORE PROCEEDING

Due to the wide variety of building structures, materials and suspension methods, these instructions assume that the installing contractor/installer will exercise good judgment in selecting the proper mounting area and hardware. As a guide, the installation, when complete, should be capable of supporting at least 5 times the actual load. Follow building code requirements to safely suspend the speakers to the building structure

Step 1:

Flip speakers so that the bottom is facing up. Unscrew existing speaker screw and discard.

Step 2:

Determine the splay angle of the speaker and the holes to use on the front joiner plate (Figure 2).

Step 3:

Install the front-rear joiner plate on the rear inserts of the speaker using the slots of the plate (Figure 1). Install the other front-rear joiner plate on the two front rigging inserts using the corresponding holes for the appropriate splay angles. Use the provided M10 screws and washers. Make sure the markings on the plates are facing up. Do not tighten screws; leave it snug until all plates are in position.

Step 4:

Slowly flip the speaker assembly so that the tops of the speakers are facing up. Install another joiner plate on the rear rigging inserts. Use the slot on the joiner plate.



3 Point suspension using adjustable tilt Cable Kit, bridle at the rear and SAS-1WA-20 One way Array Rigging System

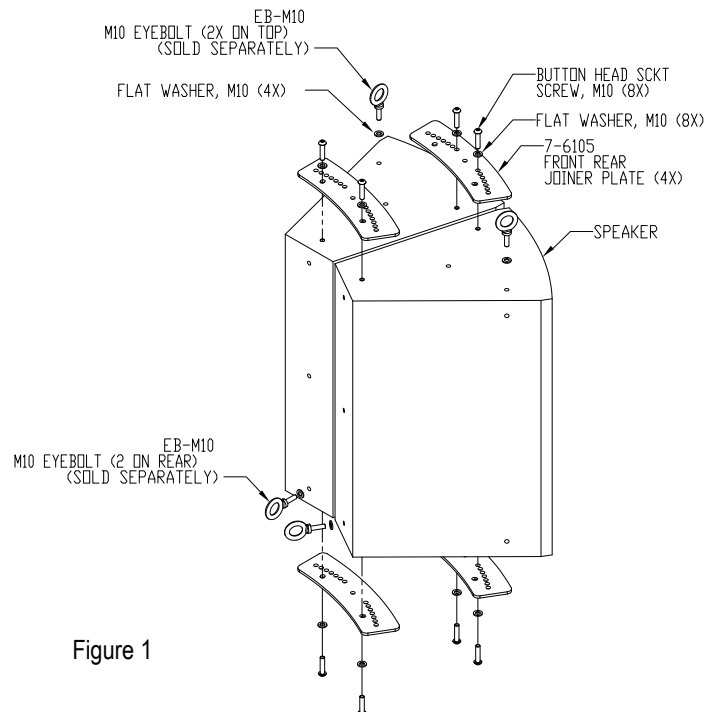

Figure 1

Step 5:

Install another front joiner plate on the two front rigging inserts using the same holes as on the bottom plate. Use the provided M10 screws and washer to secure the plate (Figure 1).

Step 6:

When all plates are in position, tighten all screws permanently.

Step 7:

Install eyebolts to the top of the speaker as shown (Figure 1).

Step 8:

Use the eyebolts on the front for the main speaker suspension points. Install eyebolts on the rear top rigging points of the speaker for pull back points. Bridle a cable or chains to create a single point to attach the pull back cable (Figure 3).

NOTE:

For steep angles, install the eyebolt on the lower rear rigging points of the speakers and then a bridle to create a single connection point for the pull back cable (Figure 3).

Step 9:

Check all hardware connections before hoisting cluster.

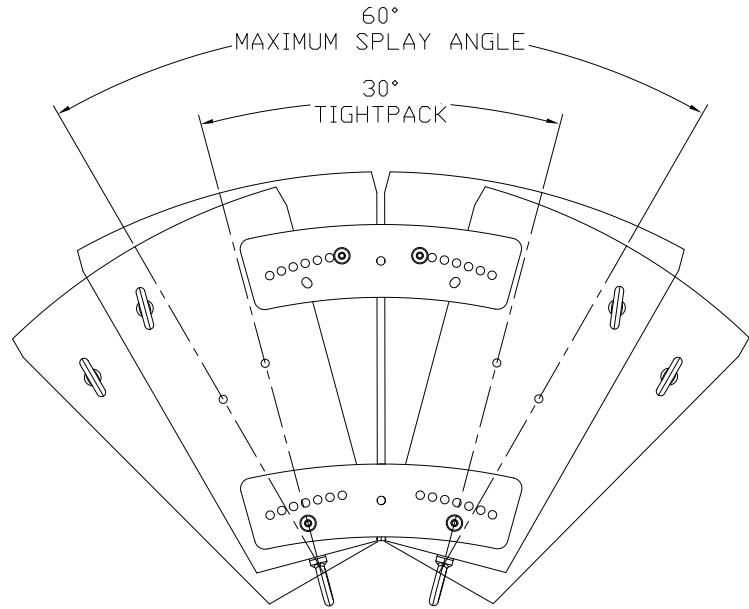

Figure 2

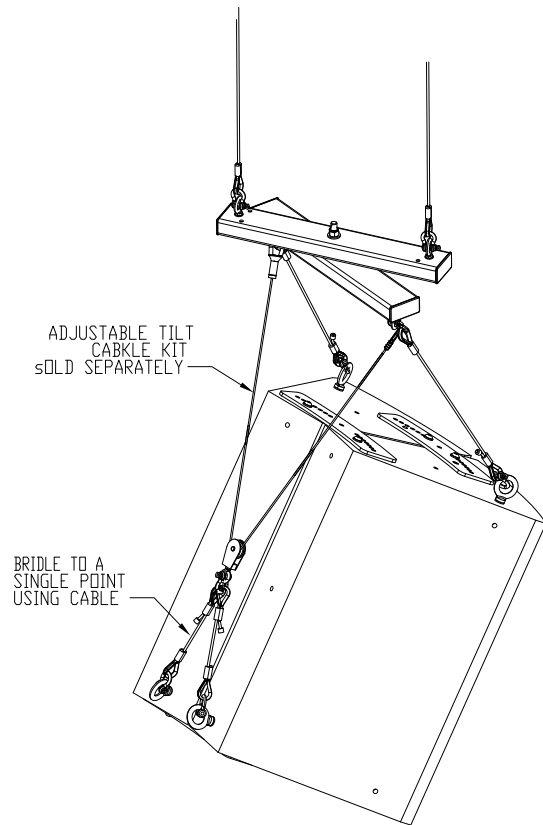

Figure 3: Bridled Pull back point with Adjustable Tilt Cable kit

The FP-AM4212-1X2 Line array kit gives designers, contractors and audio consultants the ability to create a two AM4212, AM5212 AM6212 or AM7212 Series speaker in tight pack configurations. The FasPac™ provides a method of flying a tight pack array while offering the capability of allowing cabinets to be adjusted relative to each other to find the optimum sound directivity. A series of holes are provided to easily adjust the splay angle from 0° to 30° at an increment of 2.5 degree.

Installing speakers must be performed by experienced professionals. If in doubt about the integrity of the structure you are mounting or suspending to or not sure about the proper hardware or method to use, consult a certified rigging company.

Package contents:

4 pcs	Front –rear Joiner Plate
8 pcs	Button head sckt screw, M10x 45mm long
12 pcs	M10 flat washers

CAUTION: PLEASE READ CAREFULLY BEFORE PROCEEDING

Due to the wide variety of building structures, materials and suspension methods, these instructions assume that the installing contractor/installer will exercise good judgment in selecting the proper mounting area and hardware. As a guide, the installation, when complete, should be capable of supporting at least 5 times the actual load. Follow building code requirements to safely suspend the speakers to the building structure



3 Point suspension using adjustable tilt Cable Kit and SAS-1WA-20 One way Array Rigging System

Step 1:

Unscrew existing speaker screw and discard.

Step 2:

Determine the splay angle of the speaker and the holes to use on the front joiner plate (Figure 2).

Step 3:

Install the front-rear joiner plate on the rear inserts of the speaker using the slots of the plate (Figure 1). Install the other front-rear joiner plate on the two front rigging inserts using the corresponding holes for the appropriate splay angles. Use the provided M10 screws and washers. Make sure the markings on the plates are facing up. Do not tighten screws; leave it snug until all plates are in position.

Step 4:

Slowly flip the speaker assembly up then repeat Step 3.

Step 5:

When all plates are in position, tighten all screws permanently.

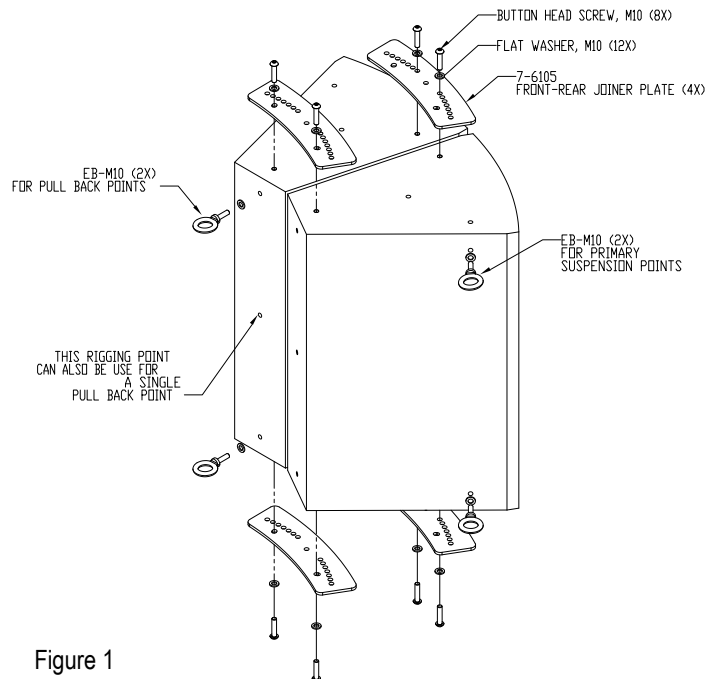

Figure 1

Step 6:

Lay the speaker cluster on its side then install eyebolts to the side rigging points (now top) of the speaker as shown (Figure 3). Install eyebolts on the rear rigging points of the lower speaker. Use either double pull back points (Figure 3A) or a single pull back point (Figure 3B).

Step 7:

Use the eyebolts on the top of the speaker cluster as the main speaker suspension points. Use the lower eyebolts of the lower speaker for pull back points and adjust the tilt angle of the speaker cluster assembly (Figure 3B and main illustration). All eyebolt can be used for four suspension points or the rear can be bridled to create a single pull back point (Figure 3A)

Step 8:

Check all hardware connections before hoisting cluster.

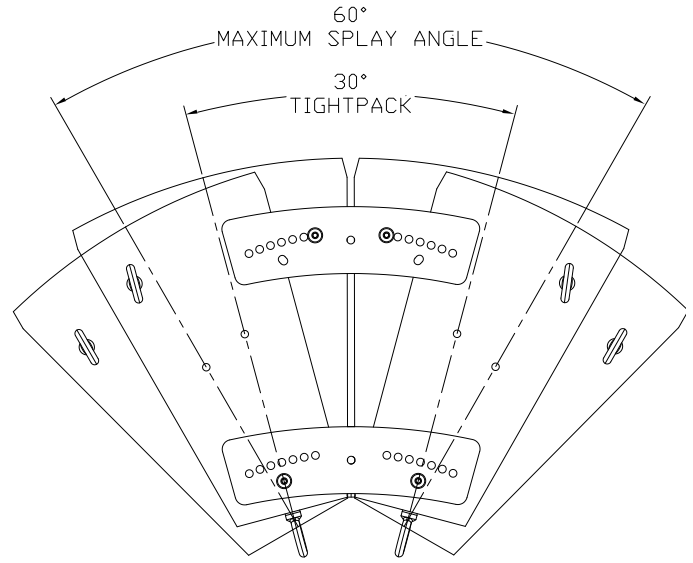

Figure 2:

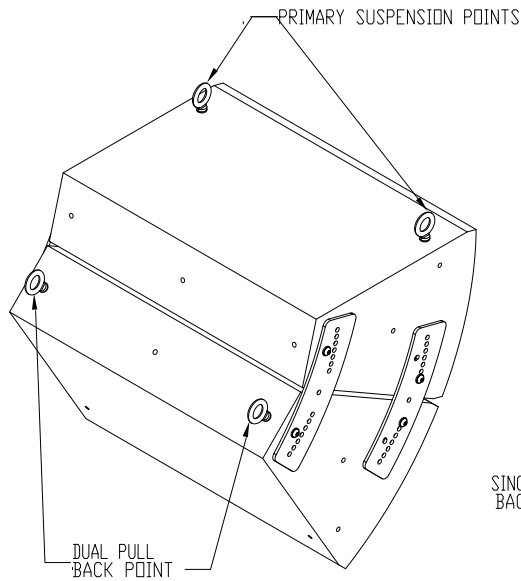

Figure 3A

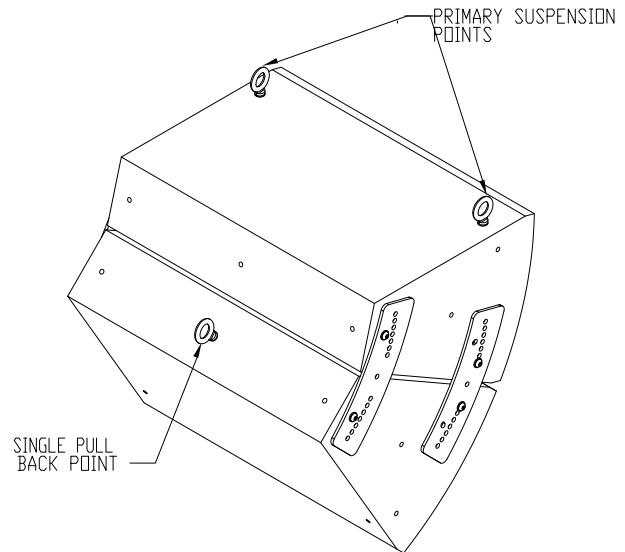

Figure 3B