

FP-PD5200-2X1

(600 lb. WLL)

CLUSTER PACK PLANAR ARRAY KIT

FASPAC™

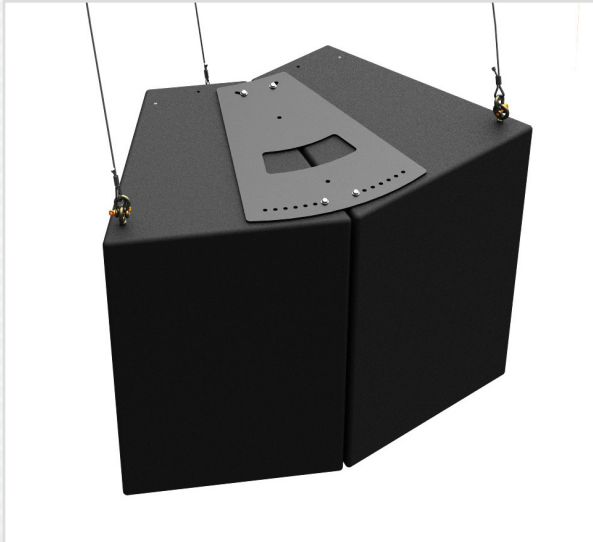

Clustering and flying PD series loudspeakers is easy, safe and very predictable. This planar array suspension kit joins two PD5200 or PD5212 cabinets together to be flown as one, tight-packed for near field placement or splayed out for further distances from the audience.

One top joiner plate and one bottom joiner plate are included in the kit along with load rated eyebolts that anchor into the speaker's rigging points and provide the actual suspension. High strength bolts are provided to secure the joiner plates.

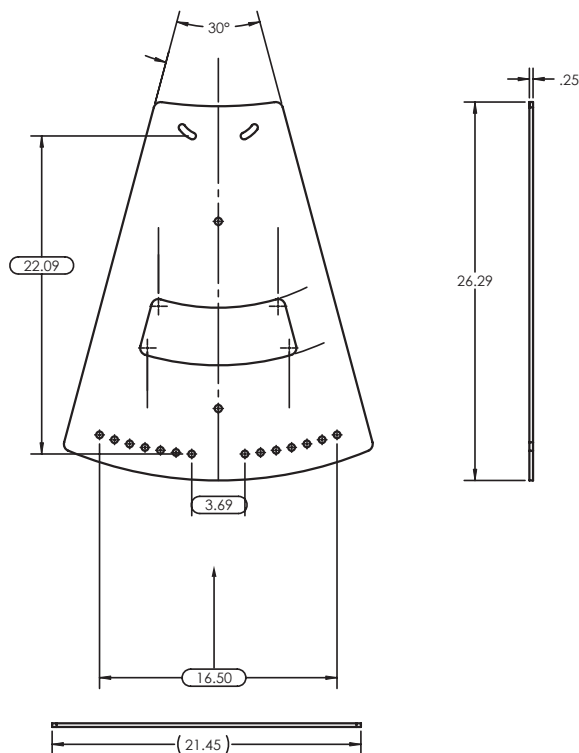

SPECIFICATIONS:

Material: Structural Steel
Finish: Powder Coat
Color: Black
Design Factor: 5:1 ratio
WLL: 600 lb. / 273 Kg.
Shipping Weight: 50 lb. / 227 Kg.

PACKAGE CONTENTS:

2pcs Joiner Plates
2pcs Eyebolt, M10X35m
2pcs Eyebolt, M10X50mm
1pc Hardware Kit



Rated for indoor use.

ALWAYS INSTALL SAFETY CABLES

WARNING: Mounting and/or suspension of audio and video equipment requires experienced professionals. Improperly installed loudspeakers can result in property damage, personal injury and/or liability to the installing contractor.