

MM-018

60 lb WLL

PAN & TILT CEILING SPEAKER MOUNT

MULTIMOUNT®



The MM-018 is a pan and tilt speaker mount that supports and aims cinema surround speakers that offer the standard four-point mounting pattern of 2-3/4" X 5".

This mount aims and anchors surround speakers from overhead ceiling grids by way of a variety of pipe extensions and adapters. Ceiling surrounds achieve up to 360 degrees of horizontal pan angle adjustments and up to 180 degrees of tilt angle adjustment.

Tilt adjustments are made at the side of the speaker adapter plate. Panning adjustments are made at the intersection of the pipe extension coupler and the speaker mount.

The MM-018's pipe coupler provides a pathway for signal wire and a safety cable to pass up through the pipe extension, making for a cosmetically pleasing, safe and predictable method for installing ceiling speakers.



Strut Attach Point

Star Grid
Compatible Component

STANDARD FEATURES:

- ▶ Independent pan and tilt controls
- ▶ Infinite locking adjustments
- ▶ No memory drift
- ▶ Single man speaker installations
- ▶ Safety cables included with extension Pipes

OPTIONAL ACCESSORIES:

- ▶ MP-500NPT-CP Ceiling Mount
- ▶ See Pipe Extensions datasheet
- ▶ See Strut Attachments datasheet
- ▶ PIPE-514-513-PR Pipe Reducer
- ▶ PIPE Coupler 2-8057 1/2-13 female

SPECIFICATIONS:

Material: Structural Steel Alloy
Finish: Powder Coat
Tilt Rotation: 180 degrees
Pan Angle: 360 degrees
Color: Black
Design Factor: 7:1 ratio
WLL: 60 lbs. (27.2 Kg) max.
Net WGT: 4 lbs. (1.8 Kg.) each
Shipping WGT: 5 lbs. (2.3 Kg.) each
Pack Count: 1 units/carton

PACKAGE CONTENTS:

1 pc Speaker Adpater Assy
1 pc Coupler Adapter, 3/4-10 Thread and 1/2NPT
2 pcs Set Screw, 1/4-20
1 pc Hex Bolt, 3/8-16 X 3/4" Long
1 pc Hex Bolt, left hand thread 3/8-16 X 3/4" Long
1 pc Star Washer, 3/8



Rated for indoor use.

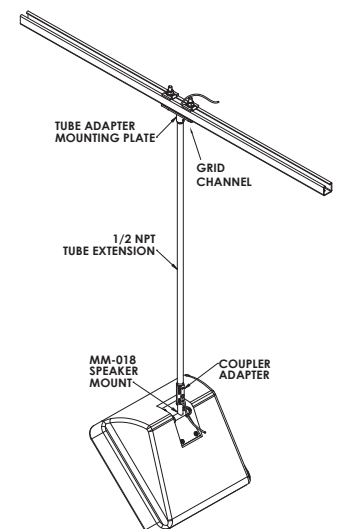
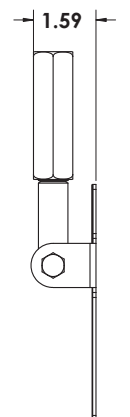
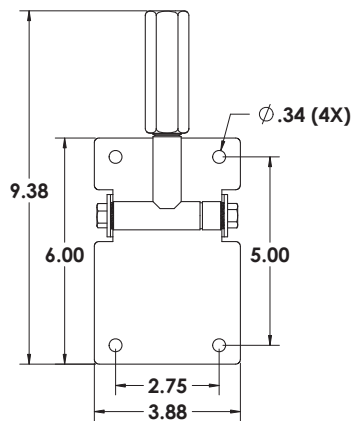
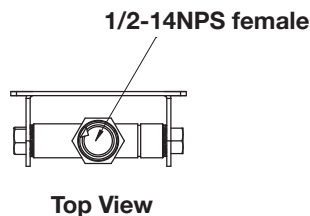

Adaptive Technologies Group
1635 E. Burnett Street | Signal Hill, CA 90755 USA
Ph: 562.424.1100 | Fax: 562.424.3520
www.adaptivetechologiesgroup.com



ALWAYS INSTALL SAFETY CABLES

WARNING: Mounting and/or suspension of equipment requires experienced professionals. Improperly installed equipment can result in property damage, personal injury and/or liability to the installing contractor.

MM-018

60 lb WLL

PAN & TILT CEILING SPEAKER MOUNT

MULTIMOUNT®

OPTIONAL ACCESSORIES:

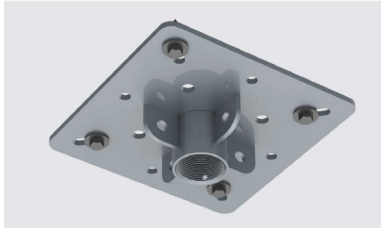

1-1/2" PIPE MOUNT
MP-150-115-CM



1/2" PIPE MOUNT
MP-500NPT-CP



GIMBALLED MOUNT
MP-500NPT-GSA
MP-1.5NPT-GSA



STRUT MOUNT
MP-500NPT-TA



1-1/2" PIPE EXTENSION

PIPE-1.5NPT-06	6" Pipe Extension
PIPE-1.5NPT-12	12" Pipe Extension
PIPE-1.5NPT-18	18" Pipe Extension
PIPE-1.5NPT-24	24" Pipe Extension
PIPE-1.5NPT-30	30" Pipe Extension
PIPE-1.5NPT-36	36" Pipe Extension
PIPE-1.5NPT-48	48" Pipe Extension
PIPE-1.5NPT-60	60" Pipe Extension
PIPE-1.5NPT-72	72" Pipe Extension



1/2" PIPE EXTENSION

PIPE-500NPT-03	3" Pipe Extension
PIPE-500NPT-06	6" Pipe Extension
PIPE-500NPT-09	9" Pipe Extension
PIPE-500NPT-12	12" Pipe Extension
PIPE-500NPT-18	18" Pipe Extension
PIPE-500NPT-24	24" Pipe Extension
PIPE-500NPT-30	30" Pipe Extension
PIPE-500NPT-36	36" Pipe Extension
PIPE-500NPT-48	48" Pipe Extension



TELESCOPING PIPE EXTENSIONS

PIPE-150-1015	10" - 15" Pipe Extension
PIPE-150-1422	14" - 22" Pipe Extension
PIPE-150-2030	20" - 30" Pipe Extension
PIPE-150-2543	25" - 43" Pipe Extension
PIPE-500-1015	10" - 15" Pipe Extension
PIPE-500-1422	14" - 22" Pipe Extension
PIPE-500-2030	20" - 30" Pipe Extension



Pipe sections include safety cables

ALWAYS INSTALL SAFETY CABLES

WARNING: Mounting and/or suspension of equipment requires experienced professionals. Improperly installed equipment can result in property damage, personal injury and/or liability to the installing contractor.