

# QL-315-S

(1760 lb. WLL)

5/16" QUICKLINK

QUICK LINK



QuickLinks join two closed-end items together, such as wire rope assemblies, turnbuckles and eyebolts quickly and easily. They offer significant working loads for their size and serve as convenient coupling devices for temporary installations but, because its side locking turn style has the potential to loosen over time, QuickLinks are not recommended for overhead use.

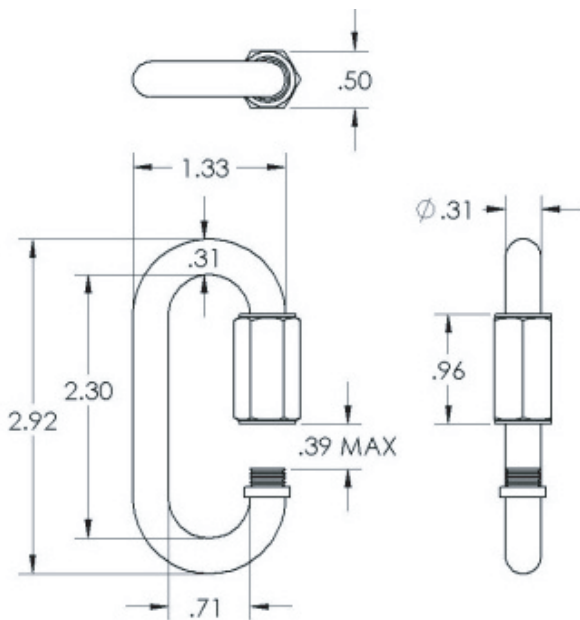

#### SPECIFICATIONS:

**Diameter:** 5/16"

**Color:** Silver

**Design Factor:** 5:1 ratio

**WLL:** 1760 lb / 800 Kg



Rated for marine environment.

**Adaptive Technologies Group**  
1635 E. Burnett Street | Signal Hill, CA 90755 USA  
Ph: 562.424.1100 | Fax: 562.424.3520  
www.adapttechgroup.com



#### ALWAYS INSTALL SAFETY CABLES

**WARNING:** Mounting and/or suspension of audio and video equipment requires experienced professionals. Improperly installed loudspeakers can result in property damage, personal injury and/or liability to the installing contractor.