

HoverTrack® Series

Assembly Installation Guide

4X4-UD46A-VWD

Important: Assembling video displays is a serious endeavor that requires experienced professionals. *Improperly assembled equipment can result in property damage, injury and/or liability to the installing contractor.* Do not attempt to install this equipment if any part of the assembly is in doubt.

Follow these instructions for the most efficient and safest assemble results.

Do not attempt to install this product if any of the parts listed below are missing. If parts are missing, contact sales@adapttechgroup.com;

Package Contents:

- 8 pcs 9-0802 4X Left H-Slat
- 8 pcs 9-0801 4X Right H-Slat
- 12 pcs 9-0803 2X V-Channel Assy.
- 2 PCS 9-0810 4X Center V-Channel assy.
- 8 pcs 9-0812 UD46A Lock Arm Bracket w/ hrdwr
- 8 pcs 9-0806 Horizontal Joiner plate
- 6 pcs 9-0814/9-0804 Vertical Joiner Plate
- 64 pcs M8 adjustable VESA buttons
- 1 pc1 Adjustment wrench
- 42 pcs Adjustable Wood screw Hanger stud
- 264 pcs Flat head phil. Screw, M6x20mm long

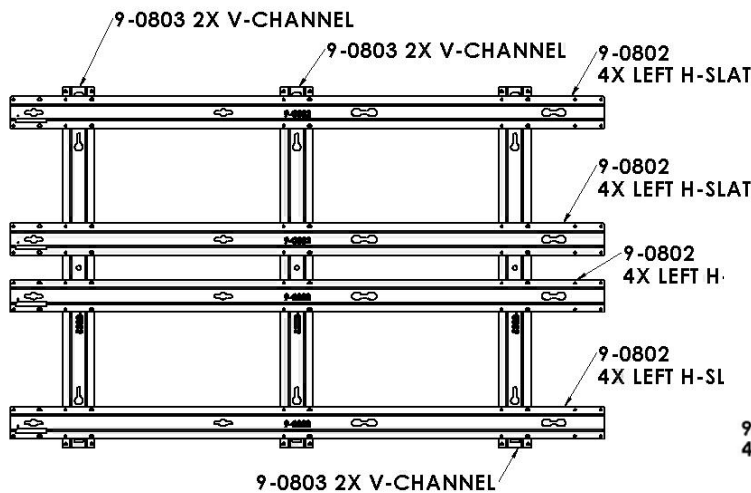

Top Left Frame (Figure 1A)

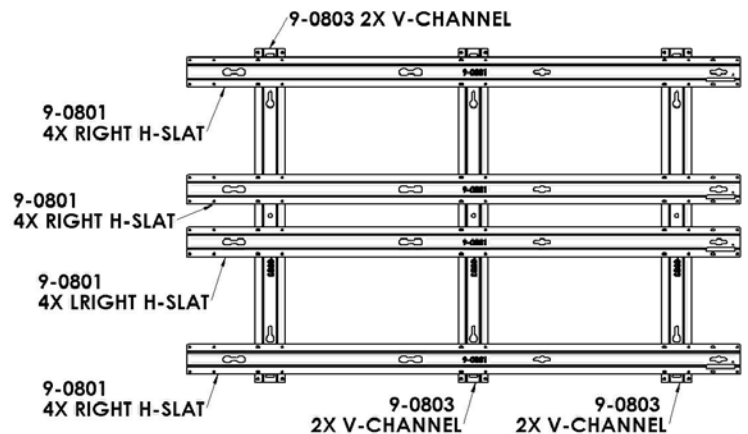

Top right Frame (Figure 1B)

Step 1: Assemble Top Left Frame

Place all of the parts in figure 1A on the floor. Start with three 9-0803 2X V-channels with their open side facing up with the narrow part of the key holes slots facing up and all in the same direction. Place four 9-0802 Left H-Slats over the V-channels with the keyhole surface facing up and the four-hole patterns lining up with that of the channels (Figure 1A). Rectangular slots in the ends of the slats should be at the outer edge of the frame. (See figure 3).

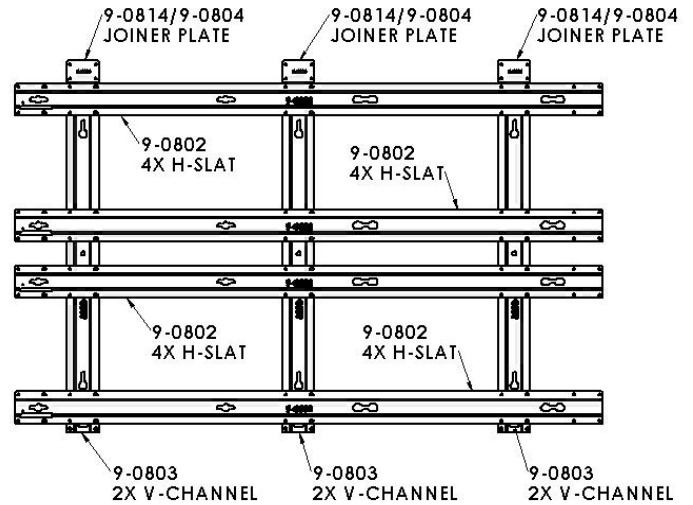

Bottom Left Frame (Figure 1C)

Step 2: Assemble Top Right Frame:

Place all of the parts in figure 1B on the floor. Start with three 9-0801 2X V-channels with their open side facing up with the narrow part of the key holes slots facing up and all in the same direction. Place four 9-0801 Right H-Slats over the V-channels with the keyhole surface facing up and the four-hole patterns lining up with that of the channels (Figure 1B). Rectangular slots in the ends of the slats should be at the outer edge of the frame. (See figure 3).

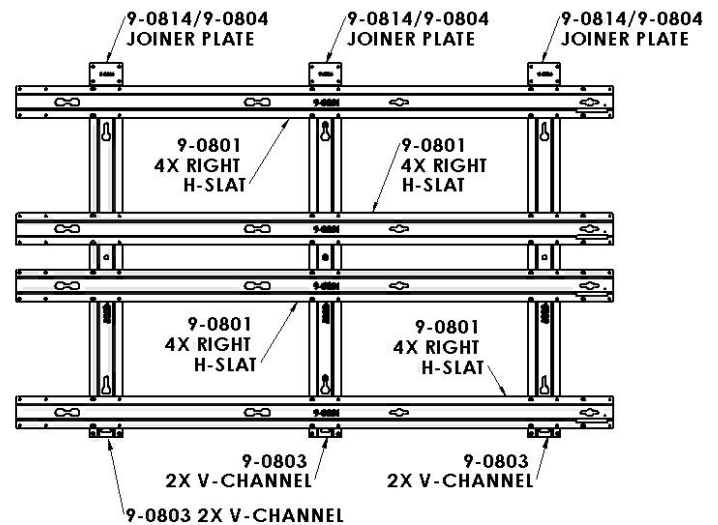

Bottom Right Frame (Figure 1D)

Step 3: Assemble Bottom Left Frame:

Place all of the parts in figure 1C on the floor. Start with three 9-0803 V-channels with their open side facing up with the narrow part of the key holes slots facing up and all in the same direction. Place four 9-0802 Left H-Slats over the V-channels with the keyhole surface facing up and the four-hole patterns lining up with that of the channels. Place three 9-0814/9-0804 vertical joiner plates at the top of the V-channel as shown in Figure 1C. Rectangular slots in the ends of the slats should be at the outer edge of the frame. (See figure 3).

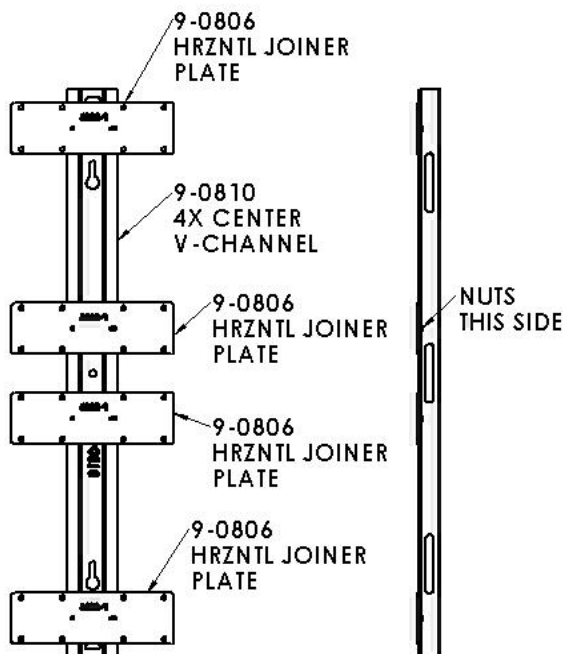

Figure 1E (Center Joiner Assembly)

Step 4: Assemble Bottom Right Frame

Place all of the parts in figure 1D on the floor. Start with three 9-0803 2X V-channels with their open side facing up with the narrow part of the key holes slots facing up and all in the same direction. Place four 9-0801 Right H-slat over the V-channel with the horizontal keyholes facing up. Place three 9-0814/9-0804 vertical joiner plates at the top of the V-channels (Figure 1D). Rectangular slots in the ends of the slats should be at the outer edge of the frame. (See figure 3).

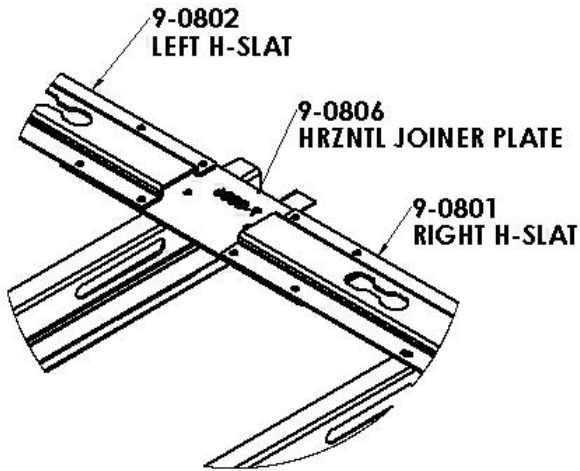

Figure 2

Step 7: Assemble the Four Sections of the Frame

Assemble the top left frame by attaching the horizontal H-slats, (9-0802 , 9-0801) to the V-channels (9-0803) using the provided M6x20mm long flat head screws. Do not tighten screws until all screws are installed. Check for squareness by measuring corners to corners then tighten screws starting with the screws on the holes of the H-slats (Figure 6)

Repeat step 4 for assembling the top right frame, lower left frame and lower right frame (Figure 6).

Step 8:

Join the top left frame and the top right frame together using the 9-0806 horizontal joiner plate and 9-0810 4Xcenter joiner V-Channels (Figure 7 & 2). Tighten screws permanently.

Step 9:

Assemble the bottom left frame and the bottom right frame together using the 9-0806 horizontal joiner plate and 9-0810 4X center joiner V-channels (Figure 8 & 2). Tighten screws permanently.

Step 10:

For wall installation, refer to product installation guide.

Step 5: Assemble Center Joiner Assemblies:

Place one 9-0810 center joiner v-channels on the floor, each with their opening facing up and with the narrow end of the keyhole slots facing up. Place four each 9-0806 Horizontal Joiner plates thread side down over the two 9-0810 center v-channels as in Figure 1E and 2.

Step 6: Install Locking Arm brackets

Assemble the 9-0812 locking arm bracket on four of the 9-0802 left H-slat and four on the 9-0801 right H-slat near the rectangular slot using the provided M4 screws, nylon washer and nylock nut (Figure 4). The locking arm brackets must be installed on the first, third, fifth and seventh horizontal H-slats starting from the top. Make sure the hook of the locking arm bracket faces up (Figure 4 & 5). Tighten screw to increase locking arm friction.

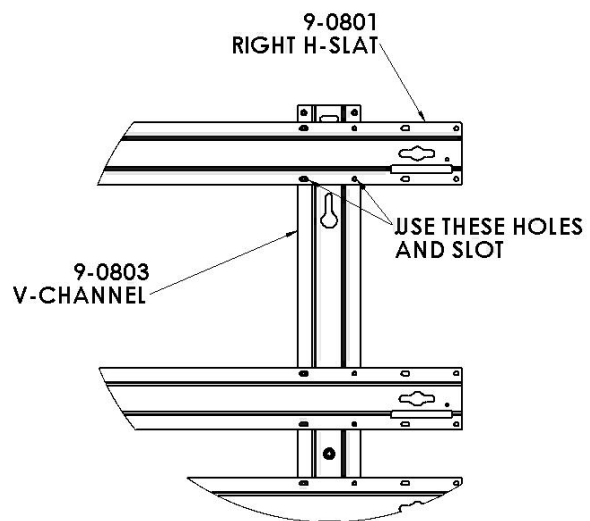

Figure 3

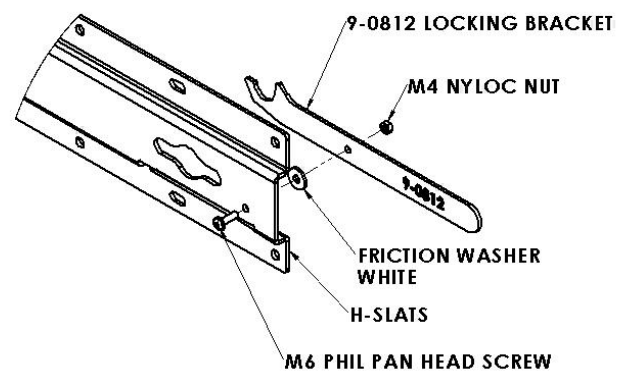

Figure 4

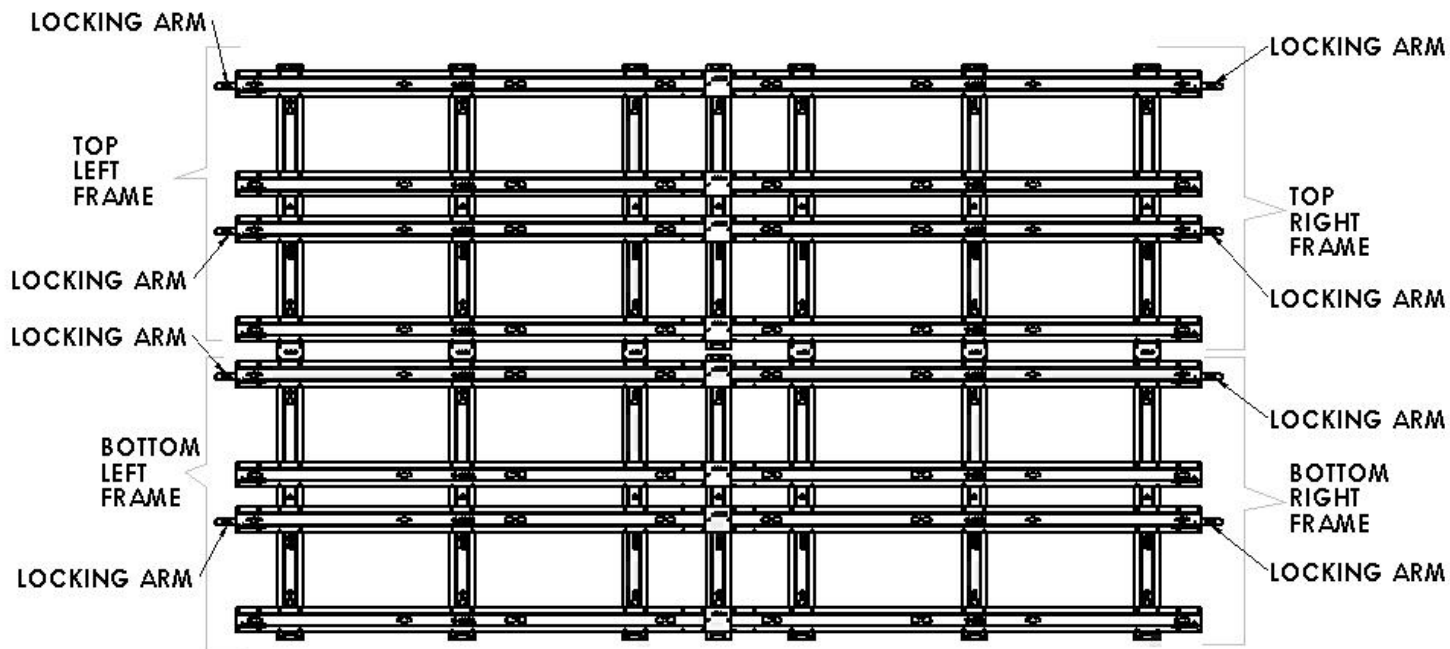

Figure 5

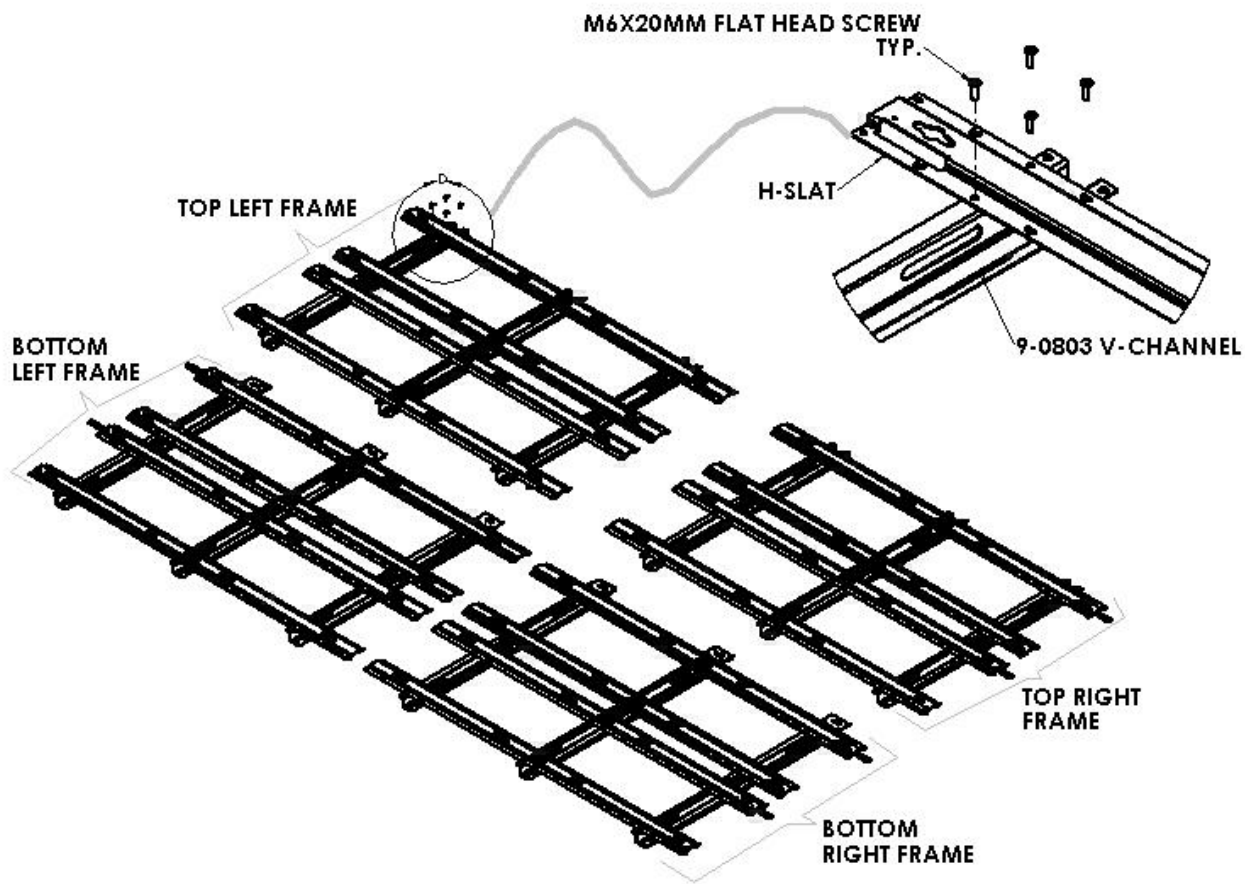

Figure 6

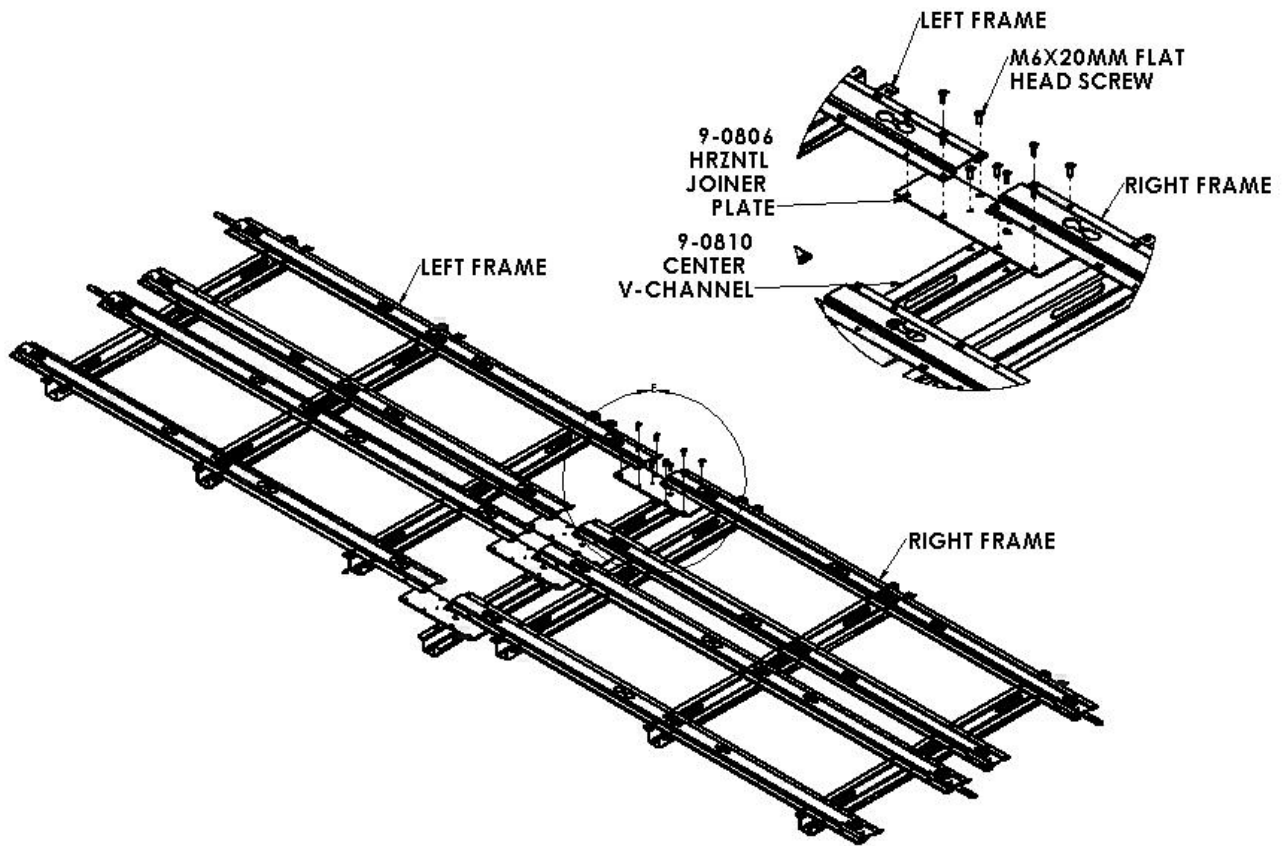

Figure 7 (Upper/Top Frame)

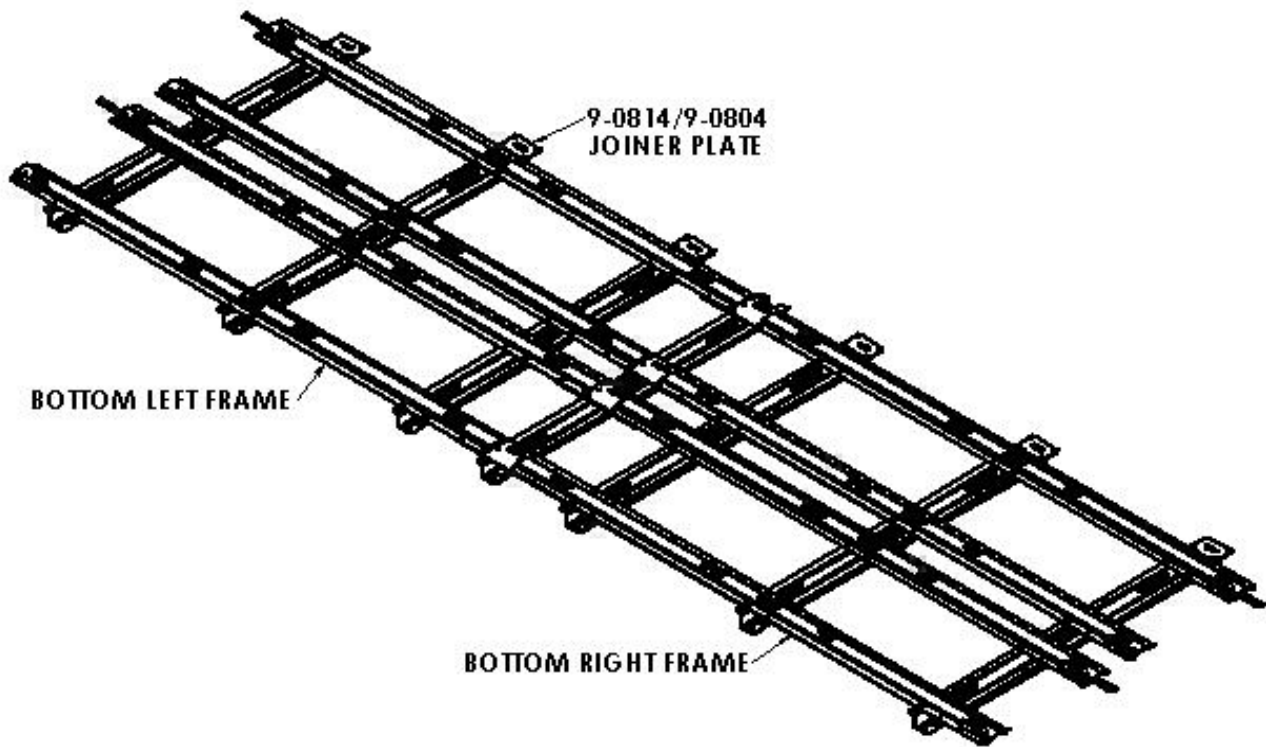

Figure 8 (Lower/Bottom Frame)